

ISA500

Underwater Altimeter & Echosounder



Installation & Operation Manual

Revision Number:	2.9
Date	24 th April 2024

1.0	Introduction	3
2.0	Specification	4
2.1	Overview	4
2.2	Dimensions	4
2.2.1	Forward Looking Housing	4
2.2.2	Right Angle Housing	4
2.3	Acoustic, Heading, Attitude & Temperature	5
2.4	Communications, Power & Physical	5
3.0	Installation	6
3.1	Electrical Installation	6
3.1.1	Connector Pin Out	6
3.1.2	Power	7
3.1.3	Serial Interface	7
3.1.4	RS232 Wiring	7
3.1.5	RS485 Wiring	8
3.1.6	Analogue Out and TTL Trigger	9
3.1.7	Establishing Communications	10
3.1.8	Connector Mating	10
3.1.9	Connector Cleaning	10
3.2	Location	11
3.2.1	Acoustics (Altitude Measurement Performance)	11
3.2.2	Magnetic Disturbers (Heading Performance)	11
3.2.3	Alignment with Vehicle (Pitch/Roll Accuracy)	12
3.2.4	Heat Sources (Temperature Accuracy)	12
3.3	Mounting	13
4.0	Operation	14
4.1	ISA500 Configuration & Use with seaView software	14
4.2	Integration with Systems	16
4.3	Understanding advanced features	17
5.0	Servicing	18

6.0	Output Strings	19
6.1	Altitude.....	19
6.2	AHRS.....	26
7.0	Theory of Operation	33
7.1	Altitude - Basic Principles.....	33
7.2	The Sonar Equation.....	35
7.2.1	Source Level (SL).....	35
7.2.2	Transmission Loss (TL).....	36
7.2.3	Noise Level (NL).....	36
7.2.4	Directional Index (DI).....	37
7.2.5	Detection Threshold (DT).....	37
7.3	Heading, Pitch & Roll.....	38
7.4	Temperature.....	38
8.0	Warranty	39
9.0	Technical Support	40

1.0 Introduction

The ISA500 provides exceptionally accurate and long-range underwater distance measurement capability. Optionally the ISA500 can also provide Heading, Pitch & Roll readings.

Designed to measure distance to the seabed (as an underwater Altimeter) the ISA500 can also be used in a number of underwater applications where a distance requires to be measured or monitored.

Optionally the ISA500 can be provided with ECHOGRAM capability. ECHOGRAM enables sonar backscatter data for each ping to be shown. This is ideal for hydrographic survey operations.

Utilising a broadband composite transducer and advanced digital signal processing techniques; enables the ISA500 to achieve long range capability with a high degree of accuracy and stability. Ranges in excess of 120 meters are achievable as are 1mm accuracy range measurements.

The availability of heading, pitch and roll provides the capability to clearly understand the orientation of the unit at all times. This can also be used to automatically correct slant range readings; providing a true altitude measurement in all dynamic conditions. Alternatively, these sensor readings can be used for navigation purposes of a ROV, AUV or other underwater items.

Housed in a compact titanium or lightweight acetal housing and available in forward looking and right angle housing configurations; ensures that the ISA500 is not only at the forefront of sensor technology, but is available in a configuration to suit any underwater distance measurement application.



ISA500 (Forward Looking, Titanium Housing)



ISA500 (Right Angle, Acetal Housing)

2.0 Specification

2.1 Overview

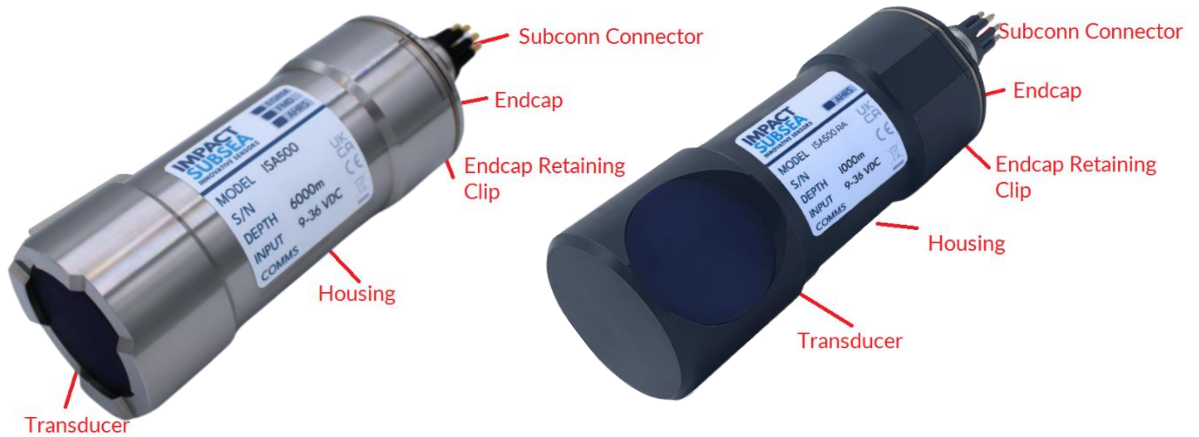

ISA500 (Forward Looking, Titanium Housing)

ISA500 (Right Angle, Acetal Housing)

2.2 Dimensions

2.2.1 Forward Looking Housing

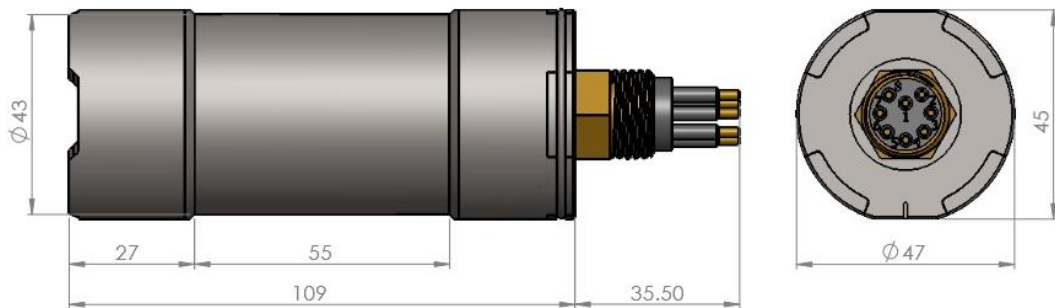

2.2.2 Right Angle Housing

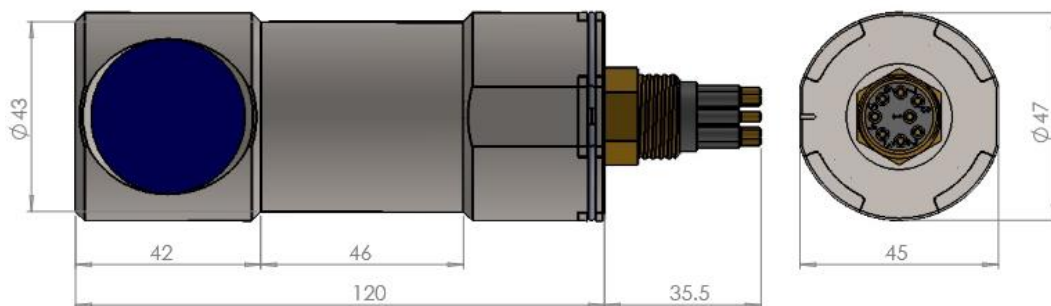

All dimensions given in mm.

2.3 Acoustic, Heading, Attitude & Temperature

Acoustic		Attitude	
Frequency	500kHz Standard (400 to 600kHz Definable)	Pitch Range	± 90°
		Roll Range	± 180°
Range	0.1 to 120+m (Maximum range dependant on seabed type: Ranges in excess of 175 meters are achievable with a strong acoustic reflector)	Accuracy	0.2°
Accuracy & Resolution	1mm	Resolution	0.1°
Beam Angle	6° conical at 500kHz	Temperature	
Signalling	Monotonic	Accuracy	0.5°
Pulse Length	User Defined	Resolution	0.1°
Heading			
Accuracy	± 1°		
Resolution	0.1°		

2.4 Communications, Power & Physical

Communications & Power		Physical	
Digital	RS232 & RS485	F/L: Weight (Air/Water)	0.5 / 0.325kg (Titanium) 0.3 / 0.11kg (Acetal)
		R/A: Weight (Air/Water)	0.52 / 0.35kg (Titanium) 0.325 / 0.125kg (Acetal)
Protocol	4800 to 115200 baud	Depth Rating	6,000 meters (Titanium) 1,000 meters (Acetal) (11,000 meter option available)
Analogue	0 to 5 V DC or 0 to 10V DC or 4-20mA*	Temperature	Operating: -10 to 40°C Storage: -20 to 60°C
Data	Continuous or on demand	Connector	Subconn MCBH8M-SS fitted as standard
Data Rate	Up to 100Hz	* Not available in all ISA500 Altimeters – check at time of ordering. ** 100% Tx power, 10Hz update rate	
Input Voltage	9 to 36V DC		
Power (No Altitude)	26mA @ 24V DC		
Power (With Altitude)	52mA @ 24V DC **		

3.0 Installation

3.1 Electrical Installation

The ISA500 is fitted with a SubConn MCBH8M-SS connector as standard. This will mate to a SubConn MCIL8F connector/cable assembly. Other connector options are available upon request.

3.1.1 Connector Pin Out

The standard connector pin out is provided below:

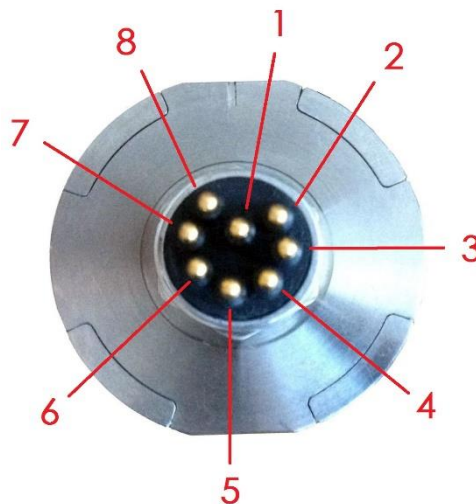

Male Connector on ISA500 Unit

Pin	Function	Mating Wire Colour
1	0VDC	Black
2	9-36VDC	White
3	Analogue Out	Red
4	0V Analogue	Green
5	0V Digital	Orange
6	Trigger	Blue
7	RS232 TX & RS485 A+	White/Black
8	RS232 RX & RS485 B-	Red/Black

3.1.2 Power

The ISA500 is polarity protected and fused with a 400mA resettable poly fuse. Internal circuitry isolates the supply from the outside environment requiring the serial interface, TTL trigger and analogue output to use the digital and analogue 0V reference pin.

3.1.3 Serial Interface

The RS232 and RS485 interfaces are isolated from the supply and has in-line fused protection on the serial lines. A prolonged transient voltage on these lines will blow the surface mount fuses which will require replacement by Impact Subsea or an approved distributor.

3.1.4 RS232 Wiring

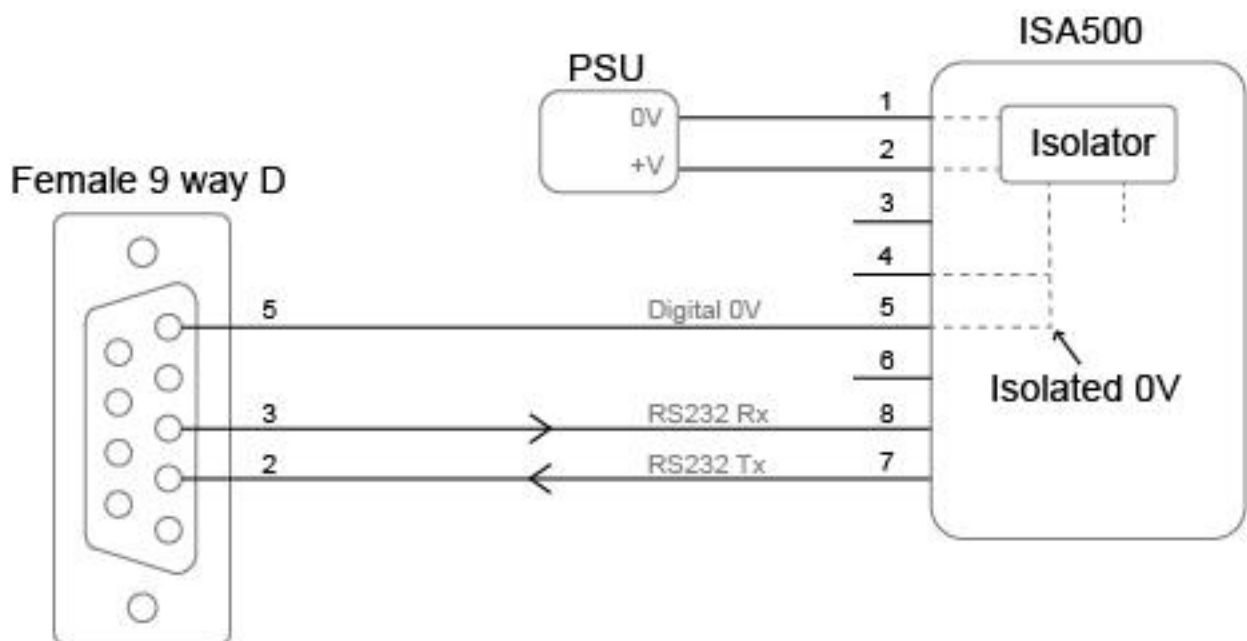

Note: RS232 will not function if the digital 0V pin is not used as the RS232 ground.

3.1.5 RS485 Wiring

The RS485 termination resistor is software selectable.

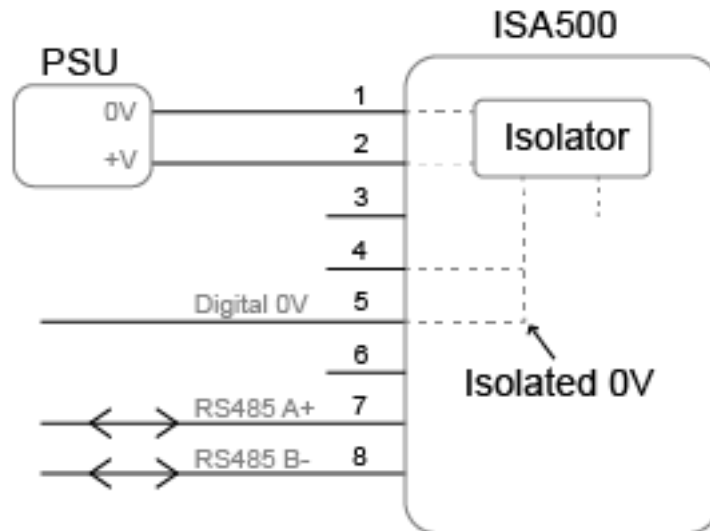

Note: The digital 0V must be connected on an RS485 interfaces, otherwise the voltage potential between one of the A+ or B- lines to ground could reach a damaging level

3.1.6 Analogue Out and TTL Trigger

The Analogue interface can be configured to output voltage or current (current option is not available on all ISA500 sensors). It is isolated from the supply and has in-line fused protection. A prolonged transient voltage on this line will blow the surface mount fuses which will require replacement by Impact Subsea or an approved distributor.

The TTL input can be used to trigger a ping, update the analogue output and transmit the user selected serial string. These events can happen when the trigger is connected to digital 0V or disconnected, the software allows the user to choose.

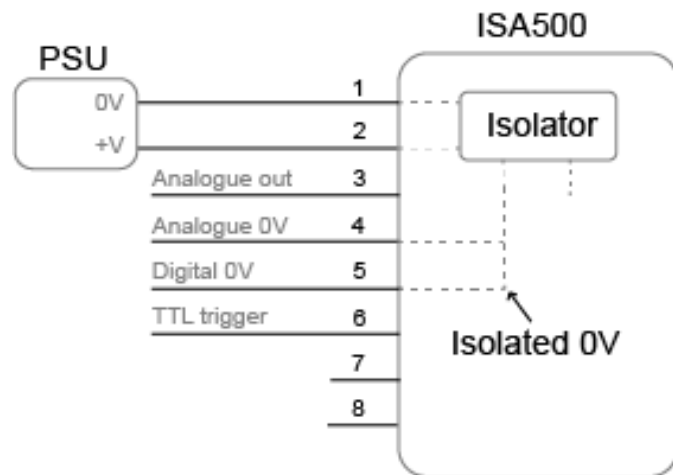

The trigger input has been designed to work with volt free contact relays, buttons and also a switching voltage from 0V to at least 3.3V or to a maximum of 10V (to support legacy TTL 0V-5V).

Internally the trigger input is pulled up to 3.3V with reference to pin 5 (digital 0V) and just requires grounding to pin 5 to trigger.

Note pin 5 (digital 0V) is isolated from pin 1 (0V power).

If the driving electronics shares the same pin 5 ground, then it can be driven with an open collector / open drain or push pull output as the input is tolerant to 10V.

If using a relay, switch or open collector / open drain to connect the trigger input to pin 5 then it must be able to sink 350µA, which should pose no problem at all.

If using a push pull output then it must be able to sink 350µA and source 2mA @ 5V or 8mA @ 10V.

From seaView you can select the setting so that it pings on connection (falling edge) or disconnection (rising edge) to pin 5.

3.1.7 Establishing Communications

If the ISA500 is tilted from vertical to upside down 3 times within the first 10 seconds of applying power then it will **temporarily** configure the serial interface to (**RS232, 9600, N81**) and output an ASCII message displaying the settings.

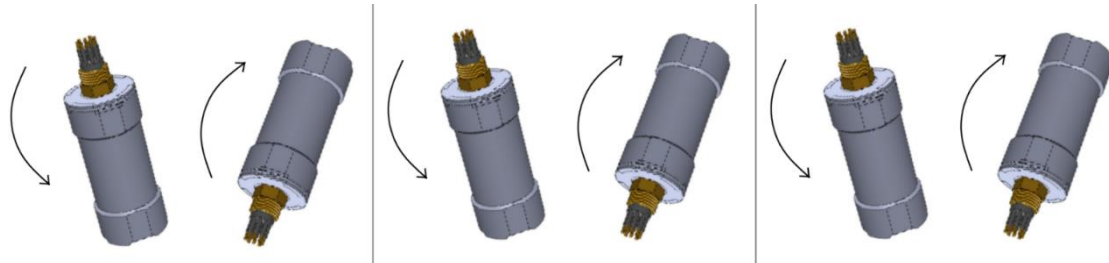

Note: When the device is power cycled the serial interface setting will revert back to the last saved configuration.

ISA500 sensors which have firmware V3 and above can also be configured to **RS485, 9600, N81**. This is done by inverting the sensor 6 times, starting within the first 10 seconds of applying power.

3.1.8 Connector Mating

When mating the cable to the SubConn connector, to maximise the life of the connector, it is important to observe the following:

- Always apply grease before mating. Molykote 44 Medium grease must be used.
- Disconnect by pulling straight, not at an angle.
- Do not pull on the cable and avoid sharp bends at cable entry.
- Do not over-tighten the bulkhead nut.

Do not expose the connector to extended periods of heat or direct sunlight. If a connector becomes very dry, it should be soaked in fresh water before use

3.1.9 Connector Cleaning

General cleaning and removal of any accumulated sand or mud on a connector should be performed using spray based cleaner (for example Isopropyl Alcohol).

New grease **must be applied** again prior to mating.

3.2 Location

When evaluating the installation location of the ISA500, there are several factors to consider to achieve optimum operation:

- **Acoustics** (Altitude/Distance Measurement)
- **Magnetic Disturbers** (Heading)
- **Alignment with Vehicle** (Pitch/Roll)
- **Heat Sources** (Temperature Measurement)

3.2.1 Acoustics (*Altitude Measurement Performance*)

The transducer must have a clear view of the seabed or target to measure distance to. Any items which obstruct this view may result in erroneous Altitude/distance measurements. If entirely obstructed, no Altitude/distance readings will be possible.

Ideally the ISA500 should not be operated in close proximity to other acoustic equipment with the same operational frequency (500kHz). Other acoustic equipment may cause the ISA500 to produce erratic Altitude readings.

If the ISA500 is found to be causing interference with other acoustic systems, the operational frequency can be adjusted to move it out of band with the other equipment – see the seaView application demonstration on our website for details or click into the ISA500 settings in seaView to see the various settings which can be adjusted.

3.2.2 Magnetic Disturbers (*Heading Performance*)

Where the heading output is to be used, the ISA500 should be mounted as far as possible from sources of magnetic interference.

Electrical items which can cause magnetic interference include motors, transformers and valve packs. Ferrous metals, or any other magnetically active materials will also have influence on the heading reading. Thus, where possible, the unit should be installed as far as possible from magnetically active materials.

3.2.3 Alignment with Vehicle (Pitch/Roll Accuracy)

When mounting **vertically**, the ISA500 should be mounted with the transducer facing downwards (to the seabed) and the indentation in the connector end cap pointing forwards, in the direction of forward vehicle travel:

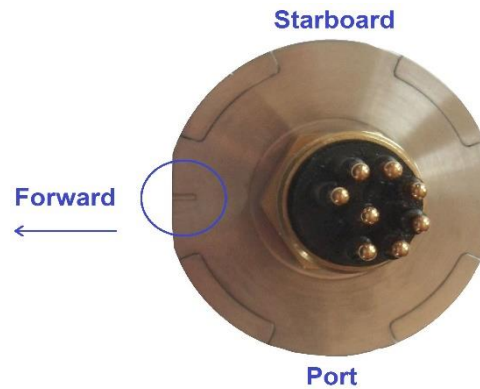

When mounting **horizontally** (for horizontal range measurements) the ISA500 should be mounted with the transducer facing in the direction of measurement to be made, with the indentation in the connector end cap pointing upwards:

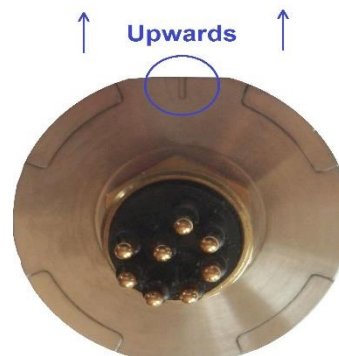

3.2.4 Heat Sources (Temperature Accuracy)

In order for the ISA500 to read the ambient temperature of the water, it should not be installed in close proximity of any heat sources (such as Hydraulic Power Packs).

Of note, the ISA500 temperature sensor is embedded in the connector endcap. For this reason, it is usual for the sensor to experience some latency when moving to a new temperature of water.

Self-heating of the ISA500 will also influence this reading.

3.3 Mounting

The ISA500 should be mounted using clamps around the mid-section of the body. The forward looking unit has a 55mm recess in the main body to enable a clamp to be tightened securely around the unit. The right angled unit has a 46mm recess.



Ideally a non-metallic clamp should be used, however in the event that this is not possible, effort should be made to electrically isolate the clamp from the ISA500 housing. This can be achieved by using rubber or plastic strips around the body of the ISA500.

The ISA500 has two flats, on either side of the body – these are to enable the unit to sit tightly against another flat surface if available. These flats also help prevent the unit moving when on the workbench for testing.

4.0 Operation

4.1 ISA500 Configuration & Use with seaView software

The ISA500 is supplied with the highly intuitive Impact Subsea seaView software on USB. The latest version of seaView can be downloaded from www.impactsubsea.com.

seaView is designed to operate any Impact Subsea sensor. Single sensors can be operated, or multiple sensors together.

The software is designed for use with a PC running the Windows 10 or 11 operating system and requires Microsoft's .net framework 4.5.2 or above.

seaView uses an advance framed binary protocol to communicate to the ISA500 and can do so over RS232 or RS485 at any standard baud rates above 4800. The parity must be none, stop bits 1 and data bits 8. If the ISA500 communication settings differ from this then perform the communications reset as described in the establishing communications section of this manual.

All ISA500 settings (min/max ranges, operational frequency, output rate, output string etc) can be configured using the seaView software. Once configured, these settings are saved to the ISA500 firmware and will remain until next changed.

For all settings, hints and tips are provided on hover over to aid finding the correct setting for the required application. It is also advisable to view the ISA500 application demo video provided on the USB drive, or available on the ISA500 page of the Impact Subsea website prior to adjusting any settings.

Note:

Firmware: If your ISA500 has firmware version 3.0 or above, it will **only** operate with seaView V3.0 and above.

If your ISA500 has an earlier version of firmware it will **only** operate with seaView 1.9.2 or earlier.

If you would like to upgrade the firmware of your ISA500 to version 3.0 or newer, please contact Impact Subsea support. Please note that if upgrading to firmware V3.0 or newer, the firmware cannot be downgraded again.

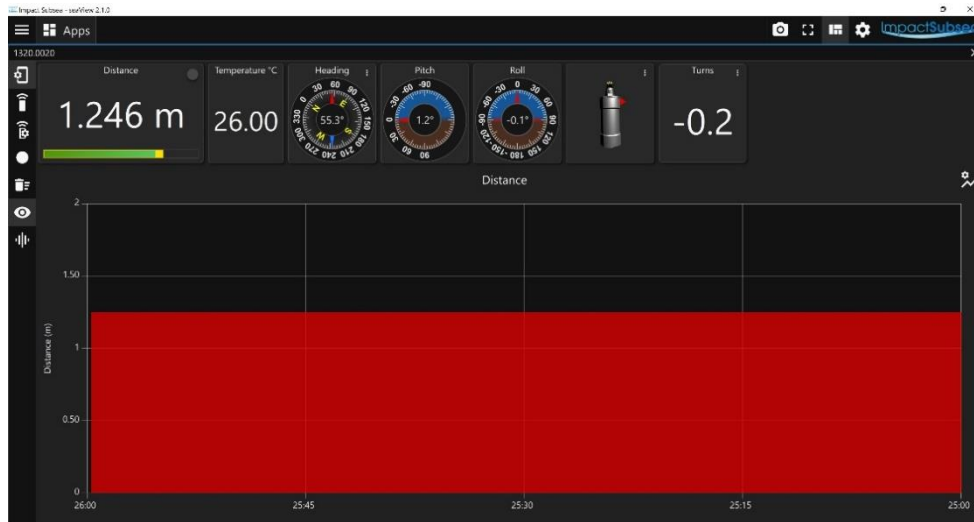

seaView V3.0 ISA500 Application

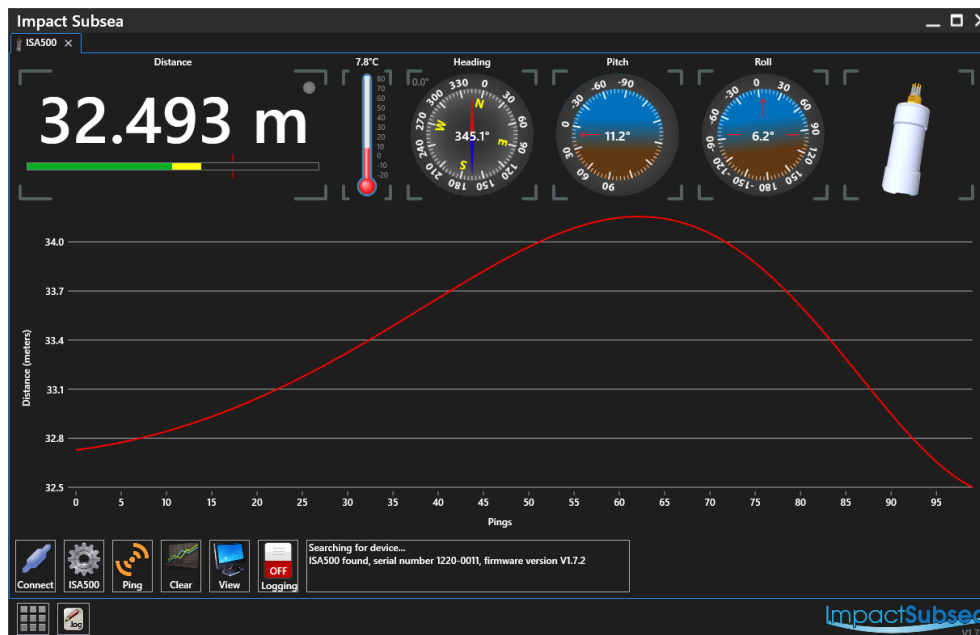

seaView V1.9.0 ISA500 Application

4.2 Integration with Systems

Conceptually there are two modes of operation, Interrogation and Autonomous.

Integration mode requires a user to request the ISA500 to make a measurement and report this back.

The ISA500 can be interrogated by a user defined interrogation string (set using seaView software), or by the TTL trigger input. Upon interrogation the ISA500 will make a measurement and report back the result over the configured output, whether this be a serial string or analogue voltage / current loop output.

Autonomous mode will make a measurement and output the result over serial or analogue at a specified time interval.

The ISA500 can be configured to operate in one or both of these modes at the same time.

ISA500's with the AHRS option make use of the same interrogated and autonomous mechanisms to output heading pitch and roll data over the serial interface.

4.3 Understanding advanced features

Some serial output strings for altitude measurement report back the energy level of the echo and also a correlation factor.

The energy level ranges from 0 to 1 where 1 represents full saturation of the ISA500 receiver. An energy level of 0.707 (square root of 2) is the theoretical perfect level as it represents the energy of a pure sine wave with an amplitude utilising the maximum dynamic range of the ISA500.

The correlation factor ranges from 0 to 1 which represents a quality factor of the returned echo. A value of 1 would represent a return echo of perfection with negligible noise and distortion.

The correlation value can be used alone as a trust factor where low values such as 0.3 mean there a good possibility it's a false reading. A more detailed picture can be built by combining this information with the energy level as shown in the table:

	Low energy levels	High energy levels
Low correlation	Weak signal probably false reading	High noise level most likely a false reading
High correlation	Weak signal but likely a good reading	Ideal conditions very trust worthy readings

These values can also give some insight for adjusting the transmit power. If the energy level is low then consider increasing the amplitude and length of the transmit pulse.

The ISA500 does not average or filter readings in any way. This provides zero lag making it ideal for control systems.

A simple reliable target tracking algorithm can be created by applying the last known altitude reading to analyse the multi echo outputs. Using the correlation and energy values will further improve the reliability.

5.0 Servicing

The ISA500 is a highly robust Altitude and Attitude measurement device. The unit has been designed to require minimal maintenance, and as such there are no user serviceable components within the unit.

The unit should be rinsed in fresh water to remove growth and salt deposits. If required a light detergent (such as that used to clean household dishes) can be used.

DO NOT USE SOLVENTS TO CLEAN THE UNIT

Following rinsing the unit should be dried with a cloth.

The connector should be cleaned, and a light coating of Molykote 44 Medium grease should be applied.

The unit should be stored in its original case, in a cool, dry place.

It is recommended that the unit be returned to Impact Subsea Ltd, on an annual basis to have a health check and service conducted.

6.0 Output Strings

The string IDs below are for ISA500 firmware version 3.0 and above.

The **number shown in brackets** after the **IDXXX (X)** is the ID of the string in firmware earlier than version 3.0. If there is no number in brackets, the string is only available from firmware version 3.0 onwards.

6.1 Altitude

ID101 (1): Impact Subsea altitude and temperature

\$ISADS,ddd.ddd,M,tt.t,C*xx<CR><LF>

ddd.ddd	Distance in meters from the transducer face to the target
tt.t	Temperature in degrees Celsius
xx	NMEA standard checksum

ID102 (2): Impact Subsea altitude, signal level, correlation and temperature

\$ISADI,ddd.ddd,M,e.eeee,c.cccc,tt.t,C*xx<CR><LF>

ddd.ddd	Distance in meters from the transducer face to the target
e.eeee	Energy level (0 to 1)
c.cccc	Correlation factor (0 to 1)
tt.t	Temperature in Celsius
xx	NMEA standard checksum

ID103 (3): Impact Subsea multi echo output

\$ISAMD,tt.t,C,ddd.ddd,...*xx<CR><LF>

tt.t	Temperature in Celsius
ddd.ddd	Distance in meters from the transducer face to the target
...	Another ddd.ddd reading
xx	NMEA standard checksum

Example string format for 3 echoes (*Note: 10 echoes maximum number of multi-echoes output via ASCII string*):

\$ISAMD,tt.t,C,ddd.ddd,ddd.ddd,ddd.ddd*xx<CR><LF>

ID104 (4): Impact Subsea multi echo output with signal level, correlation and temperature

\$ISAMI,tt.t,C,ddd.ddd,e.eeee,c.cccc,.....*xx<CR><LF>

<i>tt.t</i>	Temperature in Celsius
<i>ddd.ddd</i>	Distance in meters from the transducer face to the target
<i>e.eeee</i>	Energy level (0 to 1)
<i>c.cccc</i>	Correlation factor (0 to 1)
<i>,.....</i>	Another <i>ddd.ddd,e.eeee,c.cccc</i> reading
<i>xx</i>	NMEA standard checksum

Example string format for 2 echoes:

\$ISAMD,tt.t,C,ddd.ddd,e.eeee,c.cccc,ddd.ddd,e.eeee,c.cccc*xx<CR><LF>

ID105 (5): Tritech 3P3

ddd.dddm<CR><LF>

<i>ddd.ddd</i>	Distance in meters from the transducer face to the target
----------------	---

ID106 (6): Tritech 2P3

dd.dddm<CR><LF>

<i>dd.ddd</i>	Distance in meters from the transducer face to the target
---------------	---

ID107 (7): Tritech 3P2

ddd.ddm<CR><LF>

<i>ddd.dd</i>	Distance in meters from the transducer face to the target
---------------	---

ID108 (8): Tritech multidrop

xddd.dddm<CR><LF>

<i>x</i>	Node address. This is the first character of the interrogation string
<i>ddd.ddd</i>	Distance in meters from the transducer face to the target

ID109 (9): Benthos

Rdd.dd<CR><LF> or when there's no echo return *Rdd.ddE*<CR><LF>

dd.dd Distance in meters from the transducer face to the target

ID110 (10): Valeport

\$PRVAT,*dd.ddd*,M,0000.000dBar**xx*<CR><LF>

dd.ddd Distance in meters from the transducer face to the target

xx NMEA standard checksum

ID111 (11): SDDBT

\$SDDBT,,*f.ddd.ddd*,M,,F**xx*<CR><LF>

ddd.ddd Distance in meters from the transducer face to the target

xx NMEA standard checksum

ID112 (12): Trittech bathy mode

ID113 (13): PSA900

Ttt.t Rdd.dd<CR><LF>

tt.t Temperature in Celsius

dd.dd Distance in meters from the transducer face to the target

ID114 (14): Ulvertech Bathy

00000,*ddd*<CR><LF>

ddd Distance in centimetres from the transducer face to the target

ID115 (15): Impact Subsea time and temperature

\$ISATS,*dddddd*,us,*tt.t*,C**xx*<CR><LF>

dddddd Time in micro seconds to target

tt.t Temperature in Celsius

xx NMEA standard checksum

ID116 (16): Impact Subsea time, energy, correlation and temperature

\$ISATI,dddddd,us,e.eeee,c.cccc,tt.t,C*xx<CR><LF>

<i>dddddd</i>	Time in micro seconds to target
<i>e.eeee</i>	Energy level (0 to 1)
<i>c.cccc</i>	Correlation factor (0 to 1)
<i>tt.t</i>	Temperature in Celsius
<i>xx</i>	NMEA standard checksum

ID117 (17): Impact Subsea temperature and multi echo (time)

\$ISAMT,tt.t,C,dddddd,...*xx<CR><LF>

<i>tt.t</i>	Temperature in Celsius
<i>dddddd</i>	Time in micro seconds to target
<i>...</i>	another <i>dddddd</i> reading
<i>xx</i>	NMEA standard checksum

Example string format for 3 echoes (*Note: 10 echoes maximum number of multi echoes output via ASCII string*):

\$ISAMD,tt.t,C,dddddd,dddddd,dddddd*xx<CR><LF>

ID118 (18): Impact Subsea temperature and multi echo (time) with energy and correlation

\$ISAMV,tt.t,C,dddddd,e.eeee,c.cccc,...,....*xx<CR><LF>

<i>tt.t</i>	Temperature in Celsius
<i>dddddd</i>	Time in micro seconds to target.
<i>e.eeee</i>	Energy level (0 to 1)
<i>c.cccc</i>	Correlation factor (0 to 1)
<i>,...,....</i>	Another <i>ddd.ddd,e.eeee,c.cccc</i> reading
<i>xx</i>	NMEA standard checksum

Example string format for 2 echoes

\$ISAMV,tt.t,C,dddddd,e.eeee,c.cccc,dddddd,e.eeee,c.cccc*xx<CR><LF>

ID119 (19): NMEA \$SDDBT

\$SDDBT,a.a,f,b.b,M,c.c,F*hh<CR><LF>

a.a	Distance in feet from the transducer face to the target
b.b	Distance in meters from the transducer face to the target
c.c	Distance in fathoms from the transducer face to the target
*	Checksum delimiter
hh	Checksum field
<CR><LF>	End of sentence carriage return and line feed characters

ID120 (20): NMEA \$SDDPT

\$SDDPT,x.x,x.x*hh

First x.x	Distance in meters from the transducer face to the target
Second x.x	Offset from transducer (positive means distance from transducer to water line, negative means distance from transducer to keel)
*hh	Checksum

ID121 (21): NMEA \$GPSSS

\$GPSSS,ddd.dd,eeee,c.cc,t.t,m.m,,*f<CR><LF>

<i>ddd.dd</i>	Distance in meters from the transducer face to the target
<i>eeee</i>	Sound velocity in meters per second
<i>c.cc</i>	Offset in meters
<i>t.t</i>	Pulse length (static 0.0)
<i>m.m</i>	Output rate (time in seconds between pings) (static 0.0)
<i>*f</i>	Checksum
<CR><LF>	End of sentence carriage return and line feed characters

ID122: Tritech Micron

ddd.ddd<CR><LF>

ddd.ddd distance in meters from the transducer face to the target.

Impact Subsea Binary multi echo data (ID22):

Binary data frame containing a list of up to 100 multi echo outputs.

The frame is COBS encoded, has a CRC16 checksum and uses 0x00 as a frame delimiter.

The endianness is little endian. The binary frame format is as follows:

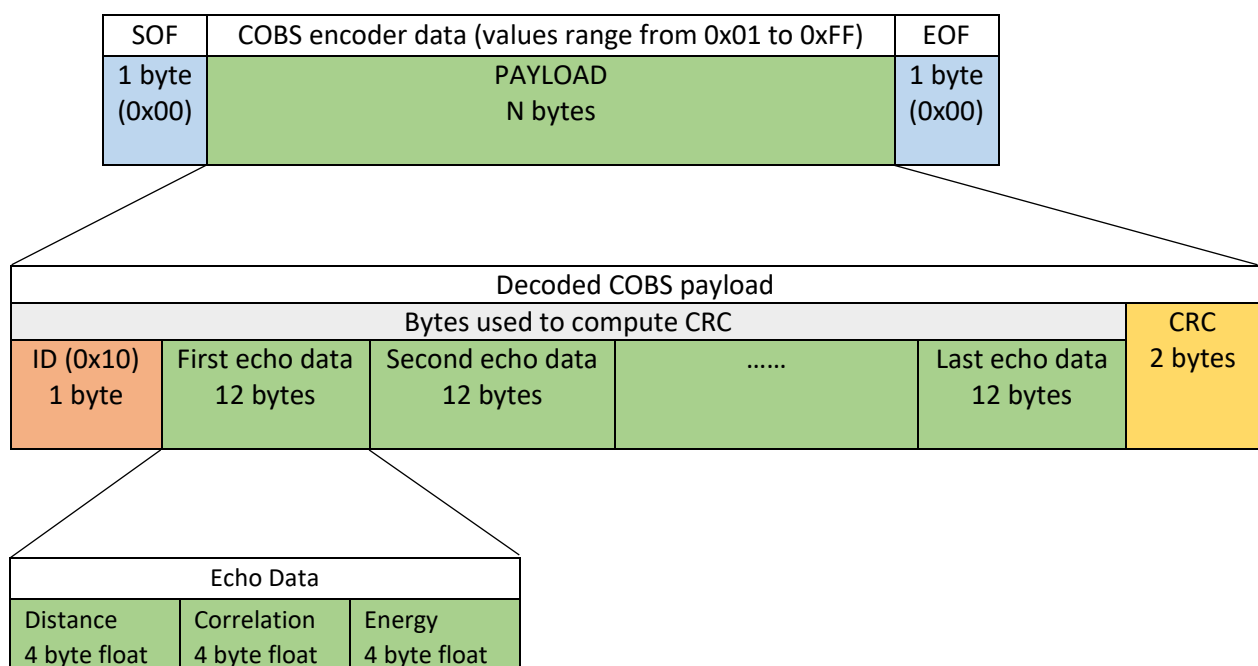

A frame can be buffered into an array by buffering all bytes between zeros. The COBS (Constant Overhead Byte Stuffing) algorithm removes all zeros from the data allowing for zero to be use for frame delimitation.

Search the internet or look at https://en.wikipedia.org/wiki/Consistent_Overhead_Byte_Stuffing for code examples and a description of the algorithm in order to decode the frame.

Once the frame is decoded the first byte should be 0x10. The last 2 bytes form the CRC 16 checksum and can optionally be used to check for data corruption. The CRC16 is a standard algorithm and uses the polynomial $x^{16} + x^{15} + x^2 + 1$. This is the one used for USB and is known as CRC-16-IBM.

The CRC algorithm is seeded with 0xFFFF and runs over all bytes in the decoded frame.

After the ID (0x10) is an array of 32 bit floats representing each echo's distance in meters to the target, normalised correlation factor (0.0 to 1.0) and normalised energy level (0.0 to 1.0).

6.2 AHRS

ID131 (1): Impact Subsea heading, pitch, roll

\$ISHPR,*hhh.h*,*spp.p*,*srrr.r***xx*<CR><LF>

<i>s</i>	sign + or -
<i>hhh.h</i>	heading in degrees (0 to 359.9)
<i>pp.p</i>	pitch in degrees (90.0 to -90.0)
<i>rrr.r</i>	roll in degrees (180.0 to -180.0)
<i>xx</i>	NMEA standard checksum

ID132 (2): Impact Subsea quaternion

Quaternions represent the orientation of a 3D body in a 4 dimensional world. This avoids the associated gimbal lock / singular problems with conventional heading, pitch, roll.

\$ISQUA,*w,x,y,z***xx*<CR><LF>

<i>w</i>	floating point number Q0
<i>x</i>	floating point number Q1
<i>y</i>	floating point number Q2
<i>z</i>	floating point number Q3
<i>xx</i>	NMEA standard checksum

ID133 (4): Impact Subsea Accelerometer, Gyro, Magnetometer

\$ISAGM,*a.aaa,a.aaa,a.aaa,g.ggg,g.ggg,g.ggg,m.mmm,m.mmm,m.mmm***xx*<CR><LF>

<i>a.aaa</i>	Accelerometer reading: X then Y then Z
<i>g.ggg</i>	Gyroscope reading: X then Y then Z
<i>m.mmm</i>	magnetometer reading: X then Y then Z
<i>xx</i>	NMEA standard checksum

All values are floating point numbers. Sign only shown if negative

Accelerometer data is provided in G

Gyroscope data is provided in degrees per second

Magnetometer data is provided in micro Tesla

ID134: Impact Subsea heading, pitch, roll, accelerometer, gyro, magnetometer

\$ISALL,*hhh.h,spp.p,srrr.r,a.aaa,a.aaa,a.aaa,g.ggg,g.ggg,g.ggg,m.mmm,m.mmm,m.mm*
*m***xx*<CR><LF>

<i>s</i>	sign + or -
<i>hhh.h</i>	heading in degrees (0 to 359.9)
<i>pp.p</i>	pitch in degrees (90.0 to -90.0)
<i>rrr.r</i>	roll in degrees (180.0 to -180.0)
<i>a.aaa</i>	Accelerometer reading: X then Y then Z
<i>g.ggg</i>	Gyroscope reading: X then Y then Z
<i>m.mmm</i>	magnetometer reading: X then Y then Z
<i>xx</i>	NMEA standard checksum

ID135: Impact Subsea w,x,y,z,accelerometer, gyro, magnetometer

\$ISQUR,w,x,y,z,a.aaa,a.aaa,a.aaa,g.ggg,g.ggg,g.ggg,m.mmm,m.mmm,m.mmm*xx<CR><LF>

<i>w</i>	floating point number Q0
<i>x</i>	floating point number Q1
<i>y</i>	floating point number Q2
<i>z</i>	floating point number Q3
<i>a.aaa</i>	Accelerometer reading: X then Y then Z
<i>g.ggg</i>	Gyroscope reading: X then Y then Z
<i>m.mmm</i>	magnetometer reading: X then Y then Z
<i>xx</i>	NMEA standard checksum

ID136 (3): TCM2 compass, pitch, roll

\$Chhh.h,Ppp.p,Rrr.r*xx<CR><LF>

<i>hhh.h</i>	heading in degrees (0 to 359.9)
<i>pp.p</i>	pitch in degrees (90.0 to -90.0)
<i>rr.r</i>	roll in degrees (90.0 to -90.0)
<i>xx</i>	NMEA standard checksum

ID137: TOKIMEK2

\$PTVF,appp.ppP,brrr.rrR,hhh.hT,fgg.gPR,hii.iRR,jkk.kAR,lmm.mN,yyyMD,zzzzAL*nn<CR>
<LF>

<i>a</i>	[-] stern down; [space] bow down
<i>ppp.pp</i>	pitch in degrees (90.00 to -90.00)
<i>b</i>	[-] starboard down; [space] port down
<i>rrr.rr</i>	roll in degrees (90.00 to -90.00)
<i>hhh.h</i>	heading in degrees (0 to 359.9)
<i>f</i>	[-] stern down; [space] bow down
<i>gg.g</i>	rate of pitch in degrees/second
<i>h</i>	[-] starboard down; [space] port down
<i>ii.i</i>	rate of roll in degrees/second
<i>j</i>	<i>[-] counter clock wise [space] clockwise</i>
<i>kk.k</i>	<i>rate of turn (degrees per second)</i>
<i>lmm.m</i>	not used
<i>yyy</i>	not used
<i>zzzz</i>	not used
<i>nn</i>	checksum of all in string between (but excluding) \$ and *

ID138: Watson

`l hhh.hh arrr.r bppp.p cggg.g dkkk.k hiii.i 0000.0 <CR><LF>`

<i>hhh.hh</i>	heading in degrees (0 to 359.99)
<i>a</i>	[-] starboard down / [+] port down
<i>rrr.r</i>	Roll rate in degrees per second
<i>b</i>	[-] stern down / [+] bow down
<i>ppp.p</i>	Pitch rate in degrees
<i>c</i>	[-] heading increasing / [+] heading decreasing
<i>ggg.g</i>	heading rate in degrees
<i>d</i>	[-] port down / [+] starboard down
<i>kkk.k</i>	roll in degrees
<i>h</i>	[-] stern down / [+] bow down
<i>iii.i</i>	pitch in degrees

ID139: HEHDT Compass

`$HEHDT,hhh.h,T*xx<CR><LF>`

<i>hhh.h</i>	heading in degrees (0 to 359.9)
<i>xx</i>	NMEA standard checksum (note: hex character are capital)

ID140: PRDID Pitch, Roll, Heading

`$PRDID,pp.p,rrr.r,hhh.h*xx<CR><LF>`

<i>pp.p</i>	Pitch in degrees (90.0 to -90.0)
<i>rrr.r</i>	Roll in degrees (180.0 to -180.0)
<i>hhh.h</i>	heading in degrees (0 to 359.9)
<i>xx</i>	NMEA standard checksum (note: hex character are capital)

ID141: TSS1

:aaaabbbb 0000U rrrrr ppppp<CR><LF>

<i>aaaa</i>	Horizontal acceleration
<i>bbbb</i>	Vertical acceleration
<i>rrrrr</i>	Roll in degrees * 100 (9000 to -9000)
<i>ppppp</i>	Pitch in degrees * 100 (9000 to -9000)

ID142: CDL TOGS

AHhhh.hh APbpp.pp ARdrrr.rr Mf Eggggggg Sx Cyyyy<CR><LF>

<i>hhh.hh</i>	Heading in degrees
<i>b</i>	[-] bow down [+] stern down
<i>pp.pp</i>	Pitch in degrees
<i>d</i>	[-] port down [+] starboard down
<i>rrr.rr</i>	Roll in degrees
<i>f</i>	Mode flag
<i>ggggggg</i>	Cycle Counter
<i>x</i>	Fault field
<i>yyyy</i>	CRC value (hexadecimal)

ID143: Micro Tilt

Papp.ppRbrr.rr

<i>a</i>	+ or -
<i>pp.pp</i>	Pitch in degrees
<i>b</i>	+ or -
<i>rr.rr</i>	Roll in degrees

ID144: EM3000

Binary Output

ID145: Seapath

\$PSXN,rrr.rr,pp.pp,hhh.hh, aa.aa*xx <CR><LF>
rrr.rr roll in degrees (180.0 to -180.0)
pp.pp pitch in degrees (90.0 to -90.0)
hhh.hh heading in degrees (0 to 359.9)
aa.aa vertical acceleration in m/s²
xx NMEA standard checksum

7.0 Theory of Operation

7.1 Altitude - Basic Principles

Throughout this section, Altitude is referred to – the ISA500 can equally be used to measure ranges underwater (vertical and horizontal). For simplicity, only Altitude is referenced here, however the same principles apply to range measurements.

This section examines how Altitude measurement is achieved by the ISA500.

For the purpose of measuring Altitude, the ISA500 is a hydro-acoustic device, which utilises sound pressure waves in order to determine Altitude.

Acoustics (also known as hydro-acoustics or sound pressure waves) are used by the ISA500 due to their high efficiency in travelling through water or liquid. Through water acoustics can travel far greater distances than signals in the light or radio frequency spectrum. Thus, are the ideal method to use for measuring distance underwater.



The ISA500 operates by emitting an acoustic pulse into the water. This pulse travels through the water until it comes into contact with the seabed. Upon contact with the seabed, part of the pulse is absorbed, and part is reflected back to the ISA500.

This reflected portion is detected by the ISA500 and the time taken for this acoustic pulse to travel from the ISA500, bounce off the seabed and return is recorded.

The distance the acoustic pulse has travelled can then be calculated by the simple equation:

$$\text{Distance} = \text{Speed} \times \text{Time}$$

In water, the speed of sound is typically around 1,500 meters per second. This is influenced by various factors (temperature, salinity & pressure). However, for the purpose of this

explanation, we will assume a speed of sound of 1,500m/s.

For example, if an acoustic pulse takes 0.1 seconds to return to the ISA500 after being sent, we can calculate its round-trip travel distance as:

$$\begin{aligned} \text{Distance} &= \text{Speed} \times \text{Time} \\ &= 1,500 \times 0.1 \\ &= 150\text{m} \end{aligned}$$

Therefore, the total distance the sound has travelled is 150 meters (journey to the seabed + journey back from seabed).

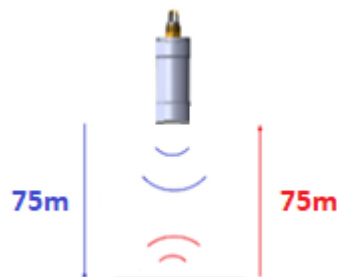

To calculate the Altitude, we simply half this value.

i.e. the range to seabed from the ISA500 Altimeter is 75 meters.

7.2 The Sonar Equation

Any equipment which relies on acoustics underwater for ranging purposes, falls into the category of a Sonar, and hence the operation is governed by the 'Sonar Equation'.

A clear understanding of this equation is essential in the design of any acoustic equipment, and useful to have an understanding of for those wishing to utilise acoustic equipment to its full potential.

The Sonar equation is a fundamental equation, which is at the heart of all hydro-acoustic systems:

$$SL - TL - (NL - DI) > DT$$

SL = Source Level

TL = Transmission Loss

NL = Noise Level

DI = Directional Index

DT = Detection Threshold

7.2.1 Source Level (SL)

The Source level is the power at which the acoustic pulse is put into the water. A greater source level will increase the range capability; however, it will also increase the power consumption.

Therefore, a trade-off between power consumption of the device, and the range required must be achieved.

There is also a physical limit to the source level which can be achieved underwater, before cavitation occurs, and acoustic transmission breaks down.

7.2.2 Transmission Loss (TL)

As the acoustic pulse propagates through the water, it experiences spreading, which causes the energy of the signal to be dispersed over an ever-increasing area. This diminishes the energy at any specific point as distance increases.

The acoustic pulse will also experience absorption by the water. The rate at which the acoustic pulse is absorbed is directly related to the pulse frequency. The higher the frequency, the higher the absorption rate.

However, typically the higher the frequency, the higher the acoustic resolution can be achieved. Thus, another trade-off must be made to use the highest frequency possible, while achieving the desired range capability.

7.2.3 Noise Level (NL)

Noise level is environment specific, which can often be the reason for acoustic systems experiencing different levels of performance in different locations or even when operating at different times.

There are numerous sources which contribute to the background noise level underwater. All of which, make the detection of the return acoustic signal increasingly more difficult.

From an environmental perspective, marine life such as snapping shrimp can cause a reasonable level of noise. Also, wind and rain can be a factor if operating close to the water surface.

Man-made sources of noise include those from machinery – such as vessel noise (thrusters and props) and also noise from ROVs and AUVs.

Multipath effects can also add to the background noise. If operating acoustic equipment in an enclosed area/close to a structure, the acoustic signals tend to 'bounce around' which can cause sporadic operation of acoustic equipment.

7.2.4 Directional Index (DI)

The Directional Index gives a reduction in noise level, governed by the properties of the transmit/receive transducer.

An omni-directional transducer will theoretically pick-up noise from all directions. A directional transducer will hear noise from only one direction. Thus, a method of reducing the apparent background noise is to utilise a highly directional transducer.

The ISA500 utilises a 6° conical acoustic beam. Meaning that any potential interference effects which exist outside of this beam, will not have a negative impact on the operation of the unit.

7.2.5 Detection Threshold (DT)

The Detection Threshold is a property of the acoustic system. It is defined as the minimal signal to noise ratio required in order to detect the acoustic signal.

The threshold can be lowered by minimising the device self-generated noise, utilising advanced acoustic signalling, and by having a highly capable matching filter, or a highly sensitive transducer on the receive side to detect the signal.

The ISA500 utilises a proprietary acoustic correlator to detect the returning acoustic signal, low noise digital electronics and a highly sensitive composite transducer to enable it to detect extremely small acoustic signals.

An appreciation of the Sonar equation will provide an understanding of the fundamental operation of the ISA500. It may also help during installation and also when fault finding as it provides an indication as to influential factors.

7.3 Heading, Pitch & Roll

In addition to Altitude, the ISA500 provides Heading, Pitch and Roll readings.

These readings are provided by a Micro-Electro-Mechanical System (MEMS) sensor within the unit.

Traditionally MEMS sensors were not particularly accurate, however they have significantly advanced in recent years. This advancement has made them ideal components to be implemented into various pieces of equipment (if you have a smart phone, the chances are that it has a built in MEMS sensor to provide you with a Compass (Heading) and spirit level (Pitch/Roll)).

The ISA500 makes use of accelerometers, gyroscopes and magnetometer data fused in a digital algorithm to provide heading, pitch and roll to an accuracy level to suit basic ROV/AUV navigation.

7.4 Temperature

A final reading which the ISA500 provides, is Temperature. The ISA500 makes use of a temperature sensor, which sits against the ISA500 end cap (the end with the connector).

This reading can be used for reference, or to alter the speed of sound value used by the ISA500. As the temperature of the water will influence the speed of sound, it is important to adjust for this to enable accuracy of measurements to be maintained.

Due to the location of the temperature sensor, self heating of the ISA500 sensor can cause the read temperature to be increased beyond the ambient water temperature.

8.0 Warranty

The ISA500 is supplied with a Limited Warranty. This warranty applies only to the ISA500 unit, and only if the ISA500 is purchased from Impact Subsea Ltd.

What does the limited warranty cover?

This Limited Warranty covers any defects in material or workmanship under normal use during the Warranty Period.

During the Warranty Period, Impact Subsea Ltd will repair or replace, at no charge, products or part of a product that prove defective because of improper material or workmanship under normal use and maintenance.

What will we do to correct the problems?

Impact Subsea Ltd will either replace or repair the Product at no charge, using new or refurbished replacement parts. Replacement or repair is at the discretion of Impact Subsea Ltd.

How long does the coverage last?

The Warranty Period for the ISA500, purchased from Impact Subsea Ltd, is 1 year from the date of dispatch from Impact Subsea Ltd.

A replacement ISA500, or part assumes the remaining warranty of the original ISA500 or 60 days from the replacement or repair, whichever is longer.

What does this limited warranty not cover?

This limited warranty does not cover any problem that is caused by conditions, malfunctions or damage not resulting from the defects in material or workmanship.

What do you have to do?

To obtain a warranty repair of your ISA500 unit, you must first contact Impact Subsea Support to determine the problem and the most appropriate solution for you.

9.0 Technical Support

Should you require technical support for your ISA500 unit, our Support team can be contacted as follows:

T. +44 (0) 1224 460 850

E. support@impactsubsea.co.uk

W. www.impactsubsea.com

An out of hours emergency number is available via the Impact Subsea website.

Utilising the above email address will ensure that a number of engineers are copied into your support request, and will ensure a prompt response.

When contacting our Support team, please provide the following details of the ISA500:

- Serial Number
- Firmware version
- Software version (if applicable)
- Fault Description
- Remedial action undertaken thus far

Every effort is made to ensure that information within this document is up to date. However, information within this document is subject to change without notice, in-line with our commitment to continuous product development and improvement.