

# ISS360 & ISS360HD

## Imaging Sonar

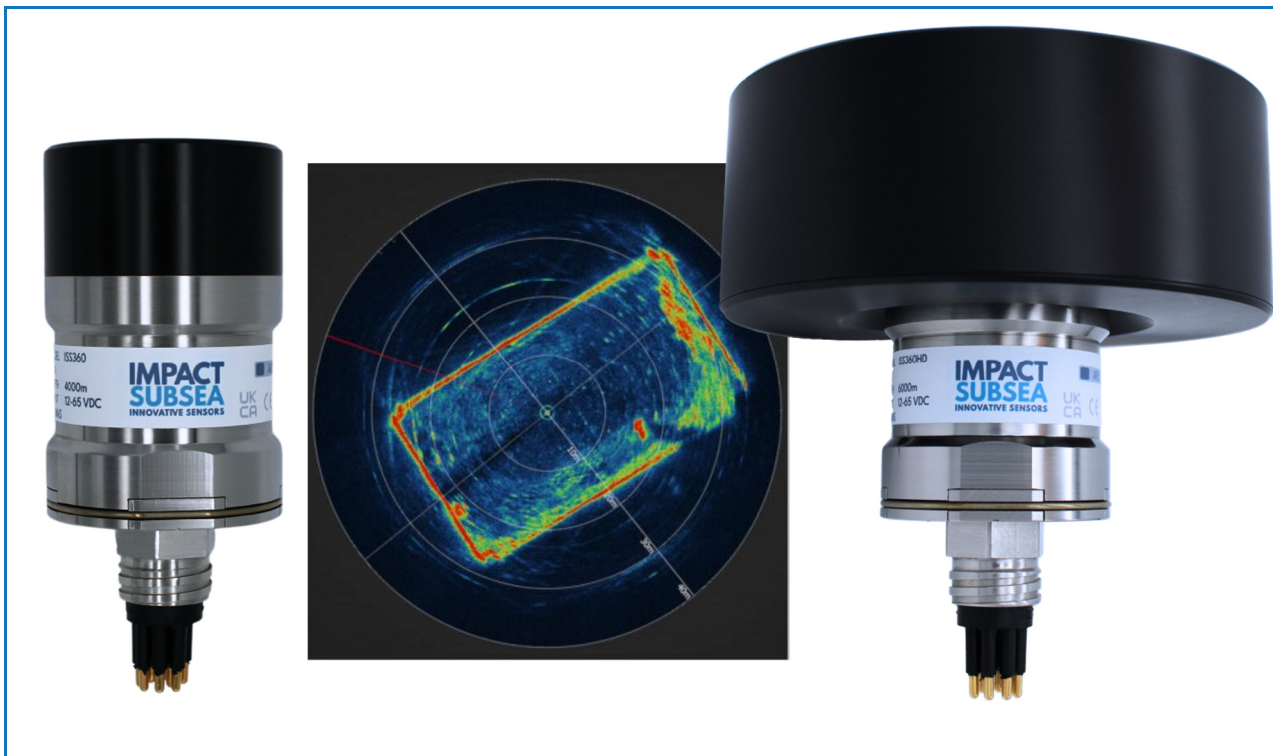

## Installation & Operation Manual

---

Revision Number: 2.3

Date 24<sup>th</sup> April 2024

---

## Contents

1.0 Introduction .....	4
2.0 ISS360 Specification .....	5
2.1 Overview .....	5
2.2 Dimensions.....	5
2.3 Acoustic & Attitude .....	6
2.4 Communication, Power & Physical .....	6
2.5 Acoustic Beam Pattern .....	7
3.0 ISS360HD Specification .....	8
3.1 Overview .....	8
3.2 Dimensions.....	8
3.3 Acoustic & Attitude .....	9
3.4 Communication, Power & Physical .....	9
3.5 Acoustic Beam Pattern .....	10
4.0 Installation.....	10
4.1 Electrical Installation .....	10
4.1.1 Connector Pin Out.....	11
4.1.2 Power .....	11
4.1.3 Serial Interface .....	12
4.1.4 RS232 Wiring.....	12
4.1.5 RS485 Wiring.....	13
4.1.6 Ethernet Wiring.....	13
4.1.7 Establishing Communications .....	14
4.1.8 Connector Mating .....	14
4.1.9 Connector Cleaning.....	15
4.2 Installation Location .....	15
4.2.1 Acoustics (Image Performance) .....	15
4.2.2 Alignment with Vehicle .....	16
4.3 Mounting.....	17

5.0 Operation .....	18
5.1 Use with seaView Software.....	18
5.1.1 Initial Connection .....	19
5.1.2 ISS360 Sonar Application .....	20
5.1.3 ISS360 Operational Settings .....	23
5.1.4 ISS360 Sensor Settings .....	25
5.1.6 Other Settings & Logging .....	28
5.1.7 Hot Keys .....	29
6.0 Maintenance & Servicing .....	30
7.0 Theory of Operation.....	31
7.1 Sonar – Basic Principles.....	31
7.2 The Sonar Equation .....	33
7.2.1 Source Level (SL) .....	33
7.2.2 Transmission Loss (TL).....	34
7.2.3 Noise Level (NL).....	34
7.2.4 Directional Index (DI) .....	35
7.2.5 Detection Threshold (DT) .....	35
8.0 Warranty .....	36
9.0 Technical Support.....	37

## 1.0 Introduction

The ISS360 family of imaging sonars provide excellent image clarity and range performance.

The ISS360 is a new generation of imaging sonar, providing exceptionally fast scanning capability.

As a very compact imaging sonar, the ISS360 is an ideal navigation and obstacle avoidance sonar for the smallest to the largest underwater vehicles. The ISS360HD offers a further enhancement on image quality and range capability.

Provided with a titanium housing the ISS360 is depth rated to 4,000 meters / 13,123 feet. Optionally the sonar can also be provided depth rated to 6,000 meters / 19,685 feet. The ISS360HD is rated to 6,000 meters / 19,685 feet as standard.

The ISS360 & ISS360HD can be provided with an integrated Attitude Reference System (ARS). This provides highly stable Pitch and Roll readings.

Both ISS360 imaging sonars utilise a broadband composite transducer coupled with CHIRP acoustics to provide excellent image clarity and range capability.

Each sonar provides a full 360° field of vision produced by a mechanically scanned transducer. The transducer utilises inductive coupling to the sonar electronics which enables operation without the use of slip rings. This ensures excellent longevity in operation.

All sonar settings are fully software configurable using the seaView software. The ISS360 sonar application within seaView is highly intuitive; ensuring range, resolution and other settings can quickly and easily be adjusted by the user.

As an alternative to the seaView software, a software development kit is available for third party integration and interface development.



ISS360



ISS360HD

## 2.0 ISS360 Specification



### 2.1 Overview

*Above: ISS360 Sonar*

### 2.2 Dimensions

The dimensions of the ISS360 sonar are shown below:

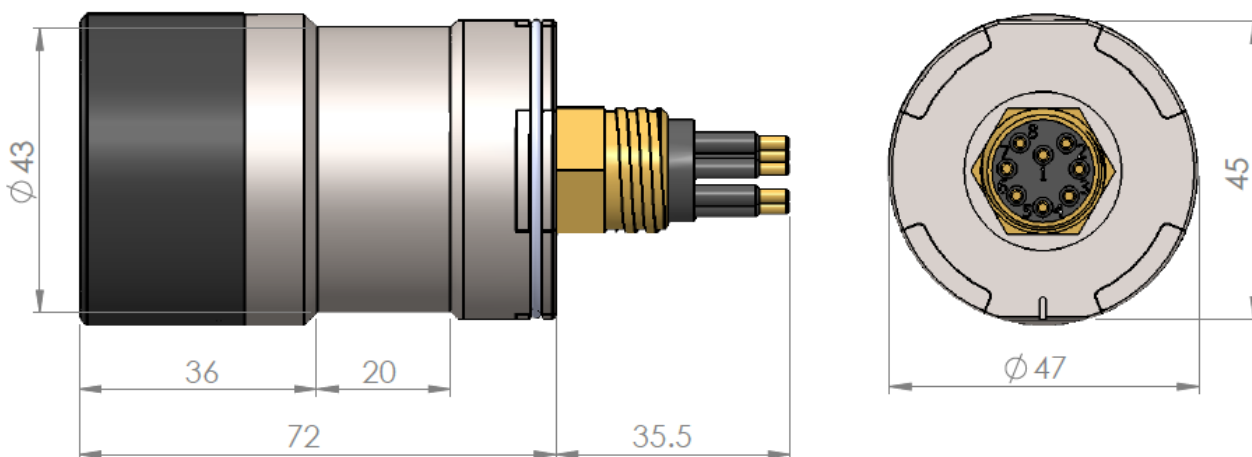

*All dimensions are in mm.*

## 2.3 Acoustic & Attitude

Acoustic		Attitude	
Frequency	700kHz Centre 650 to 750kHz Optimal Bandwidth 600 to 900kHz Bandwidth Available	Pitch Range	± 90°
		Roll Range	± 180°
Range	0.15 to 90 meters (4,000m depth rated unit) 0.15 to 80 meters (6,000m depth rated unit)	Accuracy	0.2°
Range Resolution	2.5mm (minimum)	Resolution	0.1°
Beam Angle	23° Vertical 2.2° Horizontal		
Signalling	CHIRP & Continuous Wave		
Step Size	0.225°, 0.45°, 0.9°, 1.8°, 3.6° & 7.2°		
Scan Angle	360° Continuous or Sector Scan		

## 2.4 Communication, Power & Physical

Communications & Power		Physical	
Digital	RS232, RS485 & Ethernet	Weight (Air/Fresh Water)	0.38/0.3kg (4,000m Rated) 0.37/0.3kg (6,000m Rated)
		Depth Rating	4,000m or 6,000m
Protocol	9600 to 115,200 baud	Temperature	Operating: -10°C to 40°C Storage: -20°C to 60°C
Input Voltage	12 to 65V DC	Connector	Subconn MCBH8M-SS (other options available)
Power (Standby)	95mA @ 24V DC		
Power (Scanning)*	240mA @ 24V DC		

\* Based on maximum power level and scanning speed

## 2.5 Acoustic Beam Pattern

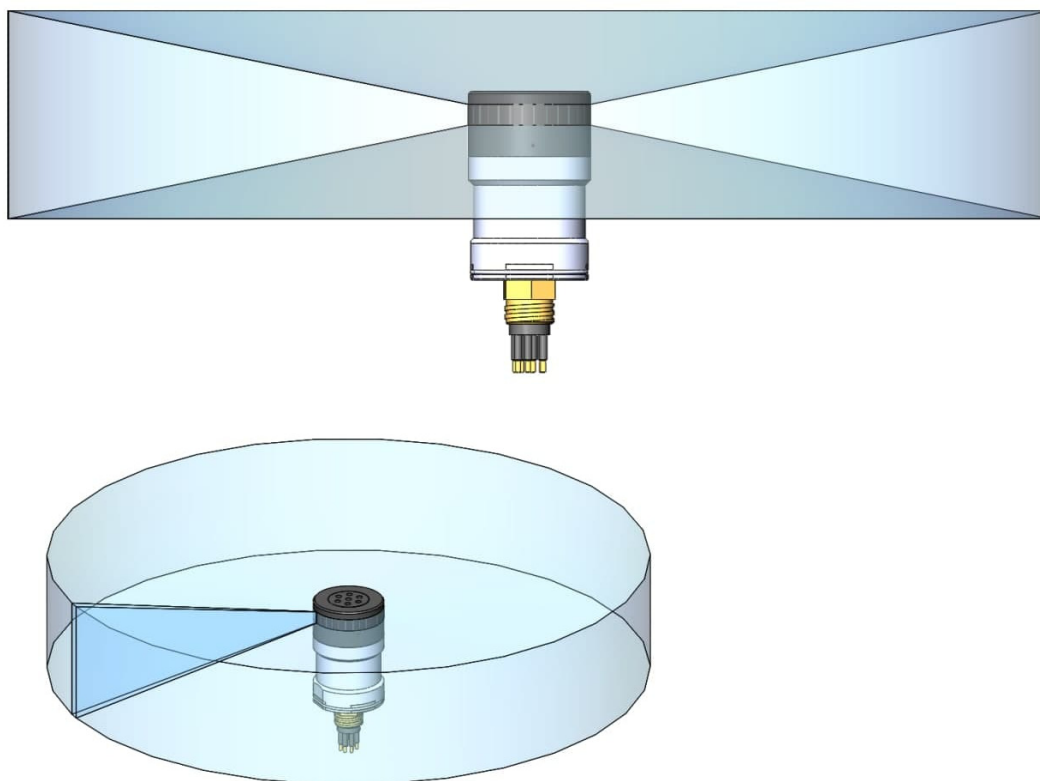

The ISS360 sonar produces an acoustic fan beam which has been configured to provide optimal coverage for the purposes of ROV navigation, obstacle avoidance and identification.

The centre of the transducer is located 9mm from the top of the black boot.



### 3.0 ISS360HD Specification

#### 3.1 Overview



Above: ISS360HD Sonar

#### 3.2 Dimensions

The dimensions of the ISS360HD sonar are shown below:

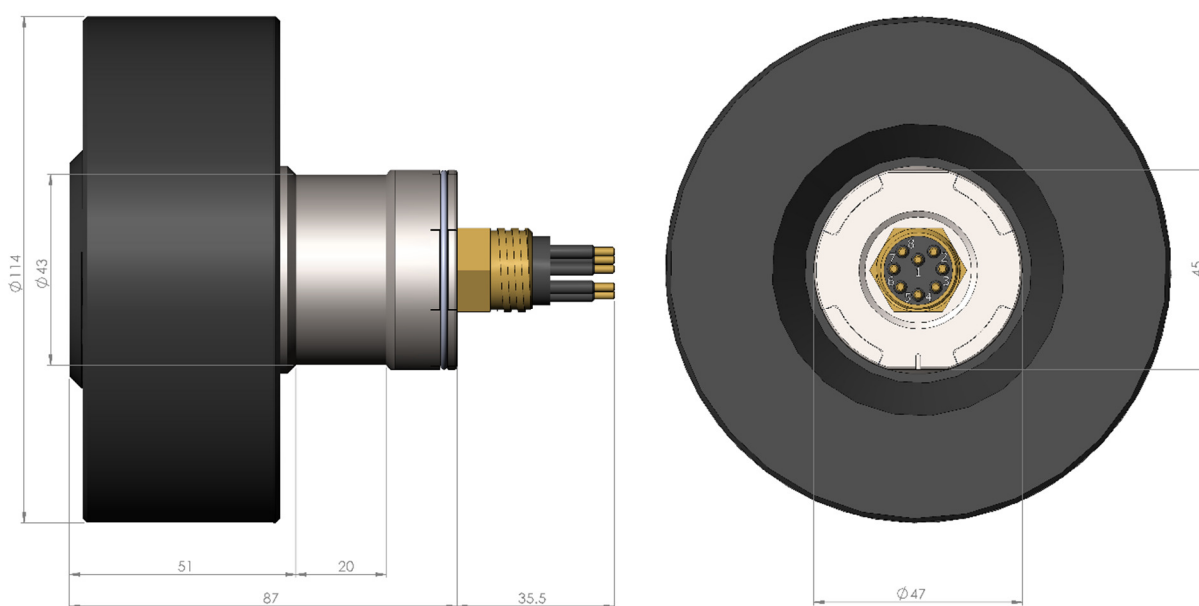

All dimensions are in mm.



### 3.3 Acoustic & Attitude

Acoustic		Attitude	
Frequency	750kHz Centre 600 to 900kHz Bandwidth Available	Pitch Range	± 90°
		Roll Range	± 180°
Range	0.45 to 100 meters	Accuracy	0.2°
Range Resolution	2.5mm (minimum)	Resolution	0.1°
Beam Angle at 700kHz	30° Vertical 1° Horizontal		
Signalling	CHIRP & Continuous Wave		
Step Size	0.225°, 0.45°, 0.9°, 1.8°, 3.6° & 7.2°		
Scan Angle	360° Continuous or Sector Scan		

### 3.4 Communication, Power & Physical

Communications & Power		Physical	
Digital	RS232, RS485 & Ethernet	Weight (Air/Fresh Water)	0.76/0.24kg
		Depth Rating	6,000m
Protocol	9600 to 115,200 baud	Temperature	Operating: -10°C to 40°C Storage: -20°C to 60°C
Input Voltage	12 to 65V DC	Connector	Subconn MCBH8M-SS (other options available)
Power (Standby)	84mA @ 24V DC		
Power (Scanning)*	261mA @ 24V DC		

\* Based on maximum power level and scanning speed

### 3.5 Acoustic Beam Pattern

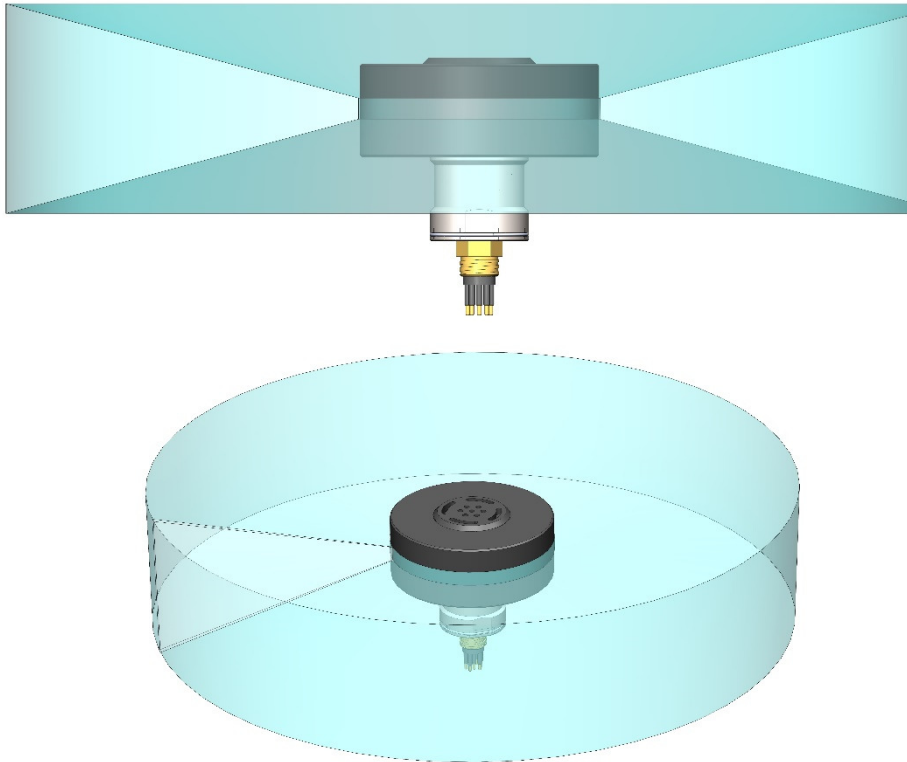

The ISS360HD sonar produces an acoustic fan beam which has been configured to provide optimal coverage for the purposes of ROV navigation, obstacle avoidance and target identification. The ISS360HD has a narrow horizontal beam (1°) by a wide vertical beamwidth (30°). This beam pattern allows more of the vertical area to be captured. This is ideal for close range target identification.

The centre of the transducer is located 21mm from the top of the black boot.

## 4.0 Installation

### 4.1 Electrical Installation

The ISS360 & ISS360HD Sonars are fitted with a SubConn MCBH8M-SS connector as standard. This will mate to a SubConn MCIL8F connector/cable assembly and use a MCDLS locking collar. Other connector options are available upon request.

## 4.1.1 Connector Pin Out

The standard connector pinout is provided below:

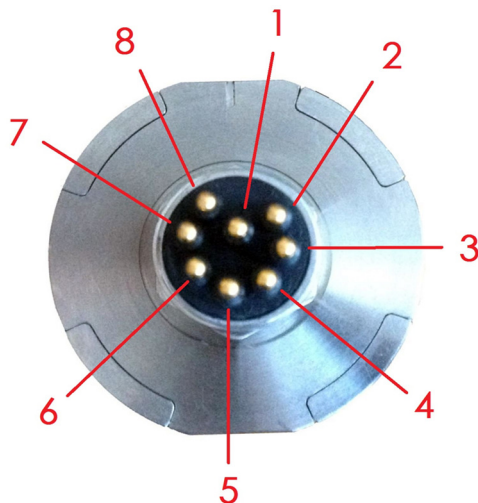

***Male Connector on ISS360 & ISS360HD Sonar***

Pin	Function	Mating Wire Colour
1	0VDC (Power)	Black
2	12-65V DC	White
3	Ethernet TX-	Red
4	Ethernet TX+	Green
5	Ethernet RX- / Serial 0V	Orange
6	Ethernet RX+ / Serial 0V	Blue
7	RS232 TX & RS485 A+	White/Black
8	RS232 RX & RS485 B-	Red/Black

## 4.1.2 Power

The ISS360 & ISS360HD Sonar power input is polarity protected and can accept a DC voltage from 12 to 65V. Do not attempt to power the ISS360 with an input voltage out with this range and be sure to take into account voltage drop on any cable.

When powering, the sonar should not be operated out of water for long periods of time. Basic checks of operation can be performed out of water, but the unit should be submerged once these are completed.

### 4.1.3 Serial Interface

The ISS360 & ISS360HD sonars have in-line fuse protection on the serial lines. A prolonged transient voltage on these lines will blow the surface mount fuses which will require replacement by Impact Subsea or an approved service agent.

### 4.1.4 RS232 Wiring

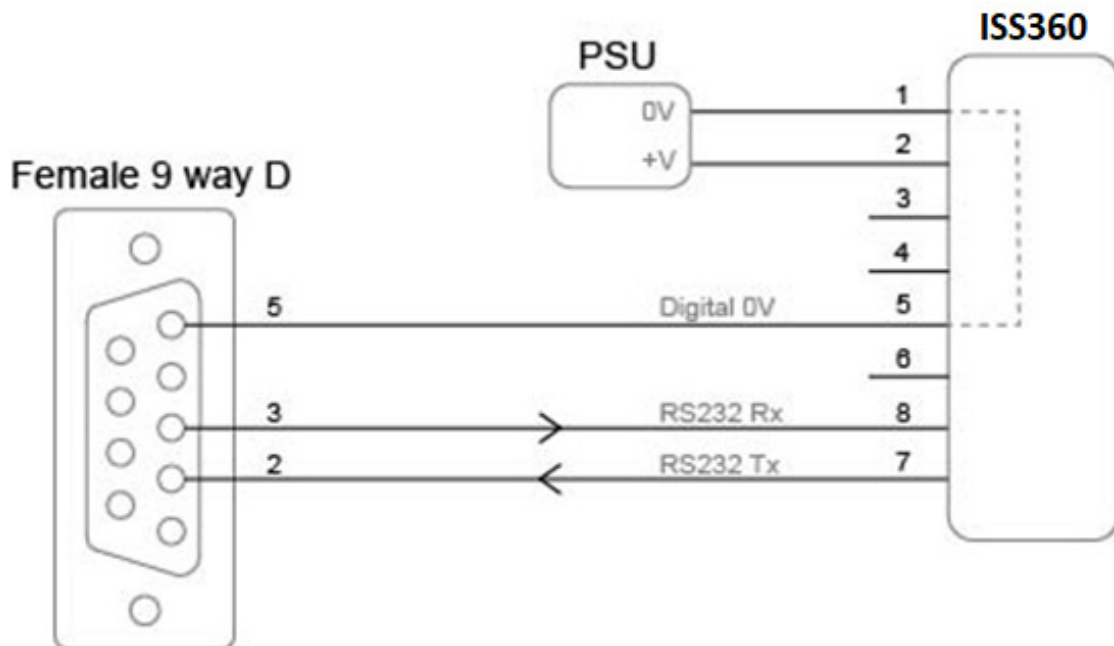

**Note: RS232 will not function if the digital 0V pin is not used as the RS232 ground**

### 4.1.5 RS485 Wiring

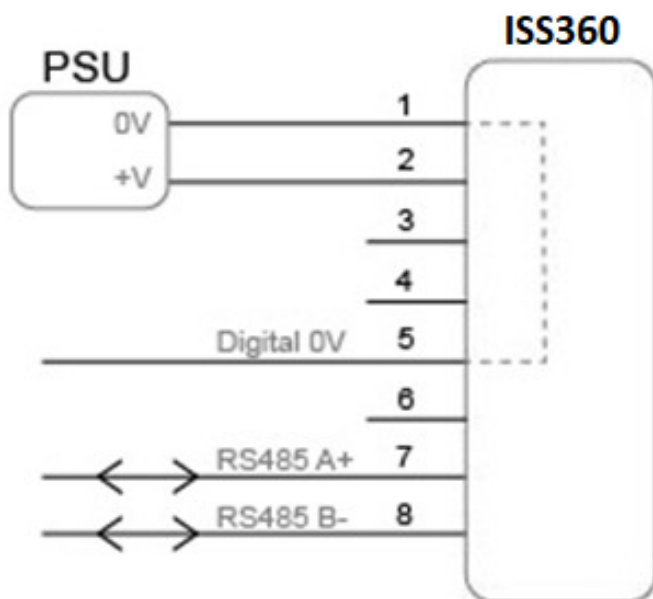

The digital 0V must be connected on an RS485 interface, otherwise the voltage potential between one of the A+ or B- lines to ground could reach a damaging level.

### 4.1.6 Ethernet Wiring

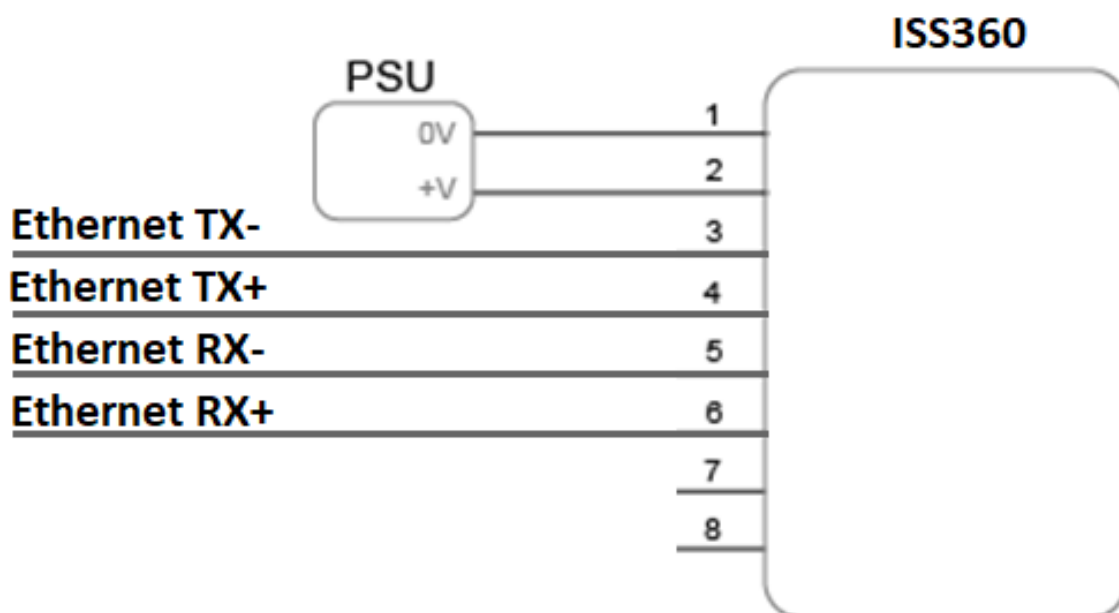

**Note:**

The ISS360 & ISS360HD **cannot** be powered over an ethernet connection. Any attempt to use a power over ethernet connection will result in permanent damage to the ISS360/ISS360HD.

## 4.1.7 Establishing Communications

The default dispatch serial settings are RS232, 115,200, N81.

If the sonar is tilted from vertical to upside down at least 3 times within the first 10 seconds of power up then it will temporarily configure the serial interface to **RS232, 9600, N81** and output an ASCII message displaying the settings.

If running firmware version 3.0 and above, inverting 6 times within the first 20 seconds of power up then it will temporarily configure the serial interface to **RS485, 9600, N81** and output an ASCII message displaying the settings.



**Note:** When the sonar is power cycled following this process, the serial interface setting will revert back to the last saved configuration.

## 4.1.8 Connector Mating

When mating the cable to the SubConn connector, to maximise the life of the connector, it is important to observe the following:

- Always apply grease before mating, Molykote 44 Medium grease must be used.
- Disconnect by pulling straight, not at an angle.
- Do not pull on the cable and avoid sharp bends at cable entry.
- Do not over-tighten the bulkhead nut.

**Do not expose the connector to extended periods of heat or direct sunlight. If a connector becomes very dry, it should be soaked in fresh water before use.**

## 4.1.9 Connector Cleaning

General cleaning and removal of any accumulated sand or mud on a connector should be performed using spray based cleaner (for example Isopropyl Alcohol).

New grease must be applied again prior to mating.

## 4.2 Installation Location

When evaluating the installation location of the sonar, there are several factors to consider to achieve optimum performance:

- Acoustics (For Imaging)
- Alignment with Vehicle (For Pitch/Roll)

### 4.2.1 Acoustics (Image Performance)

Of primary importance is the location of the sonar to achieve good imagery. The boot end of the sonar (*see diagram in section 2.1 for the ISS360 and 3.1 for the ISS360HD*) requires to have a full 360° field of vision.

The boot end of the sonar contains a single transducer mounted to a stepper motor. This transducer rotates through a 360° rotation in order to provide a 360° image of the sonar's surroundings.

When operating with a central frequency of 700kHz, the ISS360 has a 23° horizontal beam (or 30° if using the ISS360HD). It is therefore important to ensure that no part of the sonar mount/vehicle passes within this 23° or 30° beam. If it does, the part will be shown on the sonar image and may reduce range performance.

Ideally the ISS360 should not be operated in close proximity to other acoustic equipment with the same operational frequency (650 to 750kHz). Other acoustic equipment within this frequency range may cause acoustic irregularities in the sonar image.

If required, the ISS360 operational frequency can be adjusted to move it out of band with other equipment.



## 4.2.2 Alignment with Vehicle

The standard installation is to install the ISS360 sonar with the boot end facing upwards, connector facing downwards.

The sonar should be installed so that the top of the boot is perfectly level.

The indentation on the connector endcap should be installed pointing forward, in the direction of the vehicle's travel:

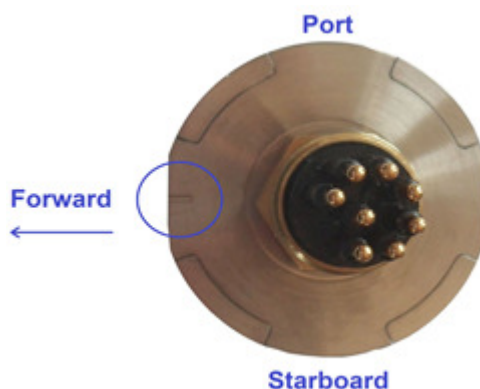

The sonar can also be installed with the connector facing upwards and the boot end facing downwards. In this installation orientation, ensure that the **'Sonar is Inverted'** box is ticked in the seaView ISS360 Orientation settings window. This will automatically correct the imagery to compensate for the inverted sonar installation.

### 4.3 Mounting

The sonar should be mounted using clamps around the mid-section of the body. The body has a 20mm recess to allow a clamp to be tightened securely around the unit.



A non-metallic clamp should be used. In the event this is not possible, effort should be made to electrically isolate the clamp from the sonar housing.

This can be achieved by using rubber or plastic strips around the body of the sonar.

The sonar has two flats on either side of the connector endcap end of the body. These are to enable the unit to sit tightly against another flat surface if available. These flats also help prevent the sonar moving when on the workbench for testing.

**Note:**

**Sonar Boot:** The black boot end of the sonar is oil filled under vacuum to remove all air. **DO NOT** unscrew the boot from the sonar as the oil will escape and the sonar will require to be refilled with oil.

## 5.0 Operation

### 5.1 Use with seaView Software

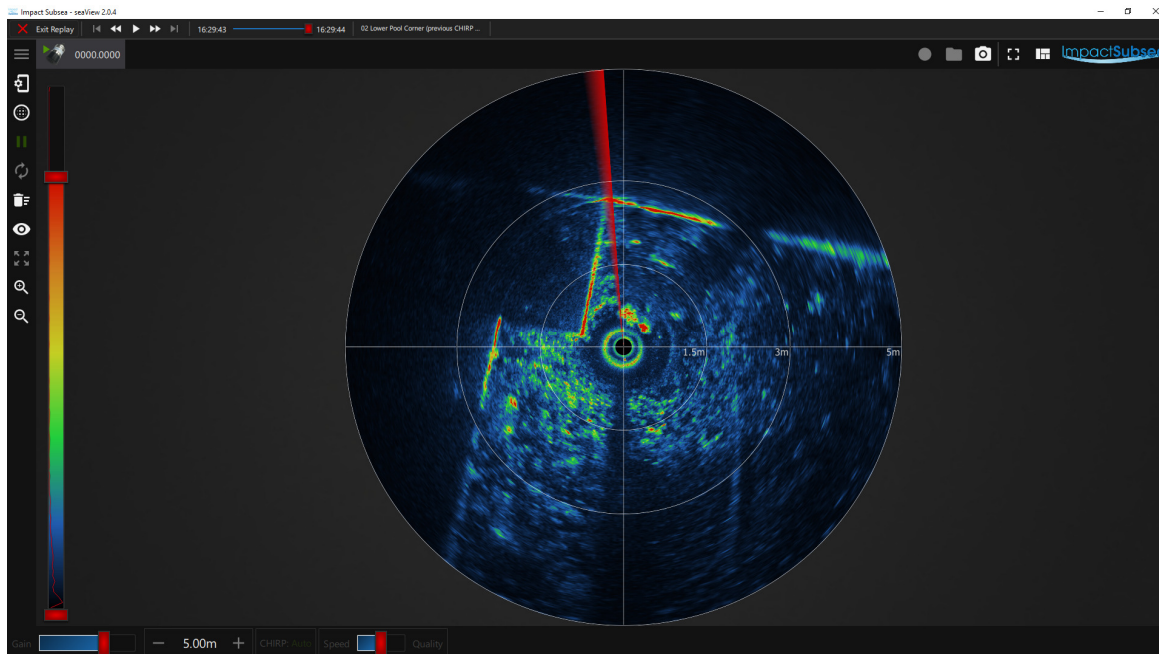

*Shown above: seaView ISS360 Sonar Application*

The sonar is supplied with the intuitive Impact Subsea seaView software on USB. The latest version of seaView can be downloaded from [www.impactsubsea.com](http://www.impactsubsea.com)

seaView software works with all of the Impact Subsea range of underwater sensors. Single sensors can be operated or multiple sensors together.

For sonars with version 2.0 firmware, seaView version 2.0 will be required. For sonars with version 3.0 firmware, seaView 3.0 or newer will be required. seaView is designed for use with a PC running the Windows 10 or 11 operating system. 32 and 64 bit versions of seaView are available.

The ISS360 application within the seaView software has been designed to be highly intuitive and easy to use. For this reason, this manual only covers the core areas of the software to help the user obtain familiarity with the application upon first use.

## 5.1.1 Initial Connection

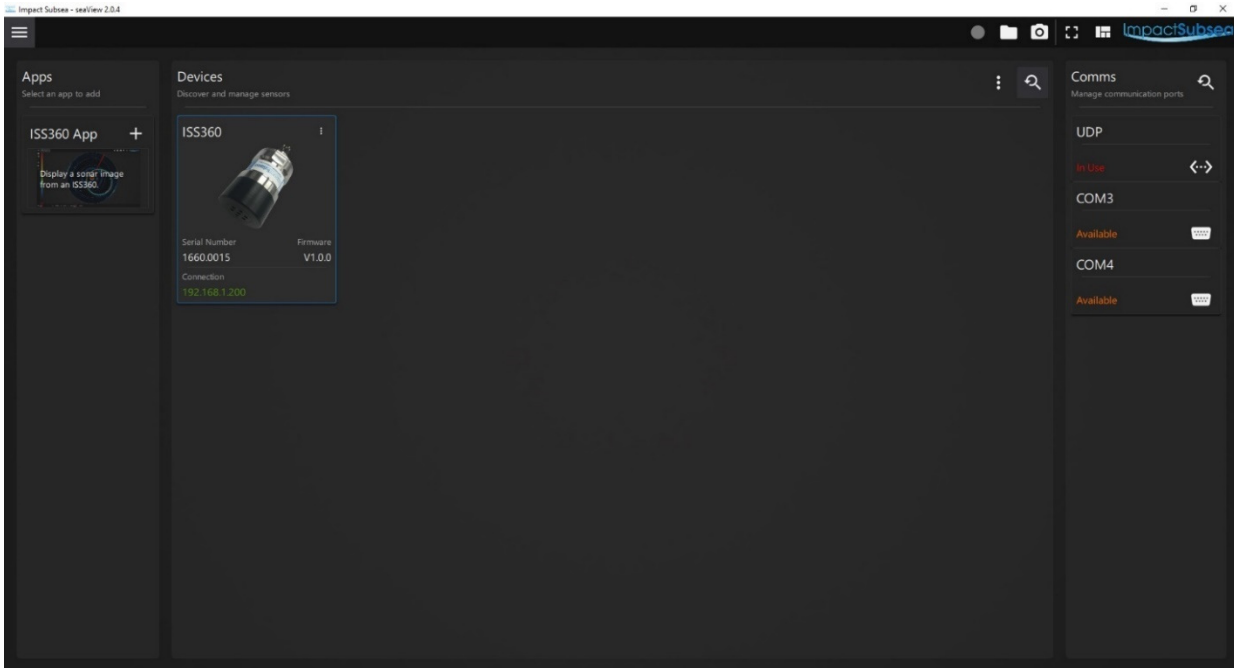

Shown above: Initial seaView launch screen

To begin, ensure the sonar is connected to the computer via RS232, RS485 or Ethernet communications and is powered on.

Upon launch of seaView, the software will automatically scan the available communication ports to detect the imaging sonar.

Once detected, the sonar will be displayed in the 'Devices' section in the centre of the display. In the above example, the ISS360 sonar with serial number 1660.0015 has been detected via an Ethernet connection and has an IP address of 192.168.1.200

Should a sonar be connected after running the software, the search button  should be pressed to search for the newly connected sonar.

**Note:**

**Ethernet communications:** If communicating via a network the ISS360 has DHCP enabled by default, so it will automatically be allocated an IP address on the network.

If running directly into a PC - allocate the PC a static IP address to enable communication. The default IP address of the ISS360 is 192.168.1.200. The PC should be configured to have a compatible IP address (for example 192.168.1.100).

Left click once on the sonar then click on the 'ISS360' app at the left-hand side of the screen. This will open the ISS360 sonar application and the sonar will automatically start to scan. Both the ISS360 and ISS360HD make use of the same application.

## 5.1.2 ISS360 Sonar Application

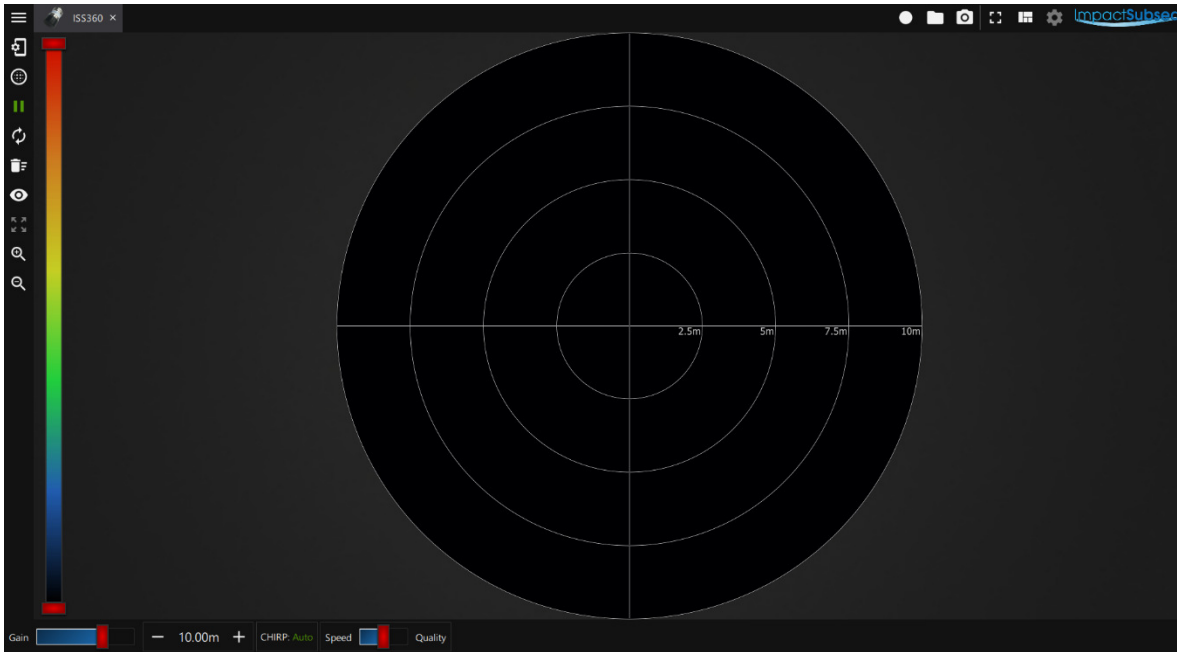

Shown above: ISS360 Application

Provided in this section is an overview of the key features of the application:

### **Colour Pallet:**

To the left of the screen is the colour pallet selector, clicking on this will allow you to select various colour pallet options for the sonar data to be rendered in.

### **Raw Data:**

The raw data returning from the sonar is presented as a red line overlaid onto the colour pallet:



To ensure all data is plotted on screen, the colour pallet should cover all of the raw data being shown.

**Image Threshold & Contrast:**

Using the red handle on the upper and lower part of the colour pallet allows the data threshold and contrast to be adjusted.

This allows the sonar image to be adjusted to suit the requirements of the application at hand:

- Weaker targets can be removed from screen by raising the lowest red handle.
- Higher contrast can be provided by lowering the uppermost red handle.

Several examples of adjusting these variables on the same image are shown below:

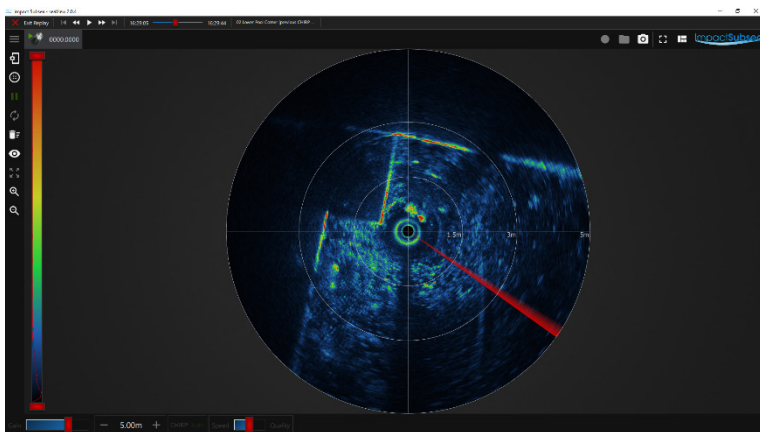

Standard setting – all data shown

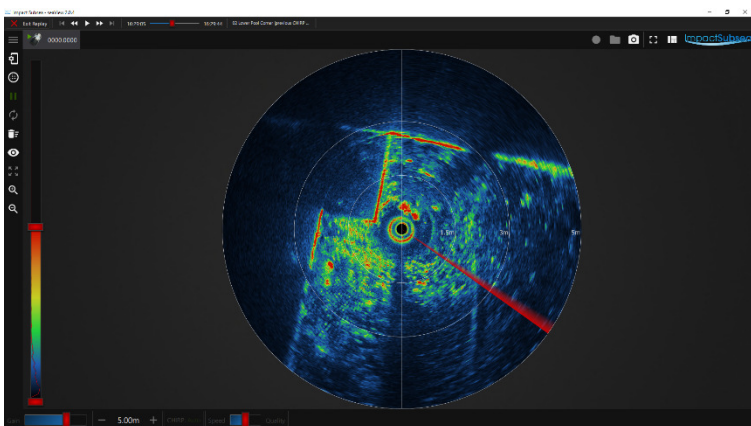

Upper Red Handle lowered - increasing contrast

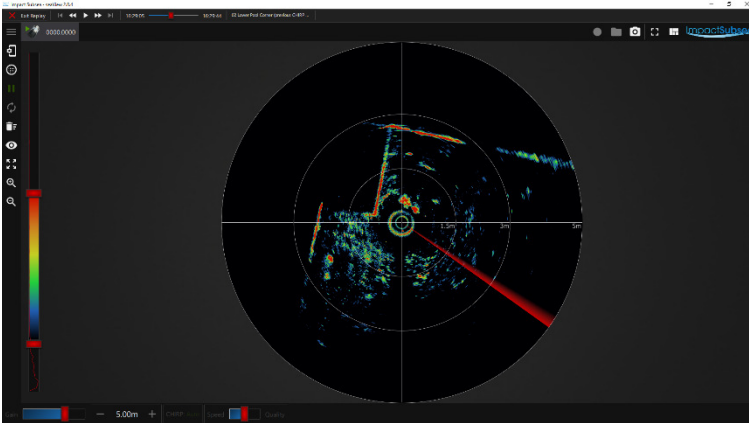

Lower Red Handle raised – removing weaker targets

### Regular Access Controls:

Along the lower part of the screen, the controls which require most regular access are provided:



- **Gain Slider**
  - The amount of amplification of the raw signal can be adjusted here
- **Range**
  - The distance the sonar is to look over can be adjusted
- **Speed/Quality Slider**
  - The resolution and scanning speed of the sonar can be set here
  - **Speed:** Moving towards 'Speed' will enable a large step size and lower bins. This will increase the scan rate of the sonar and reduce the resolution – ideal for navigation & obstacle avoidance
  - **Quality:** Moving towards 'Quality' will enable a smaller step size and higher bins. This will increase the resolution of the sonar image and decrease the scan rate – ideal for target identification or survey work



### 5.1.3 ISS360 Operational Settings

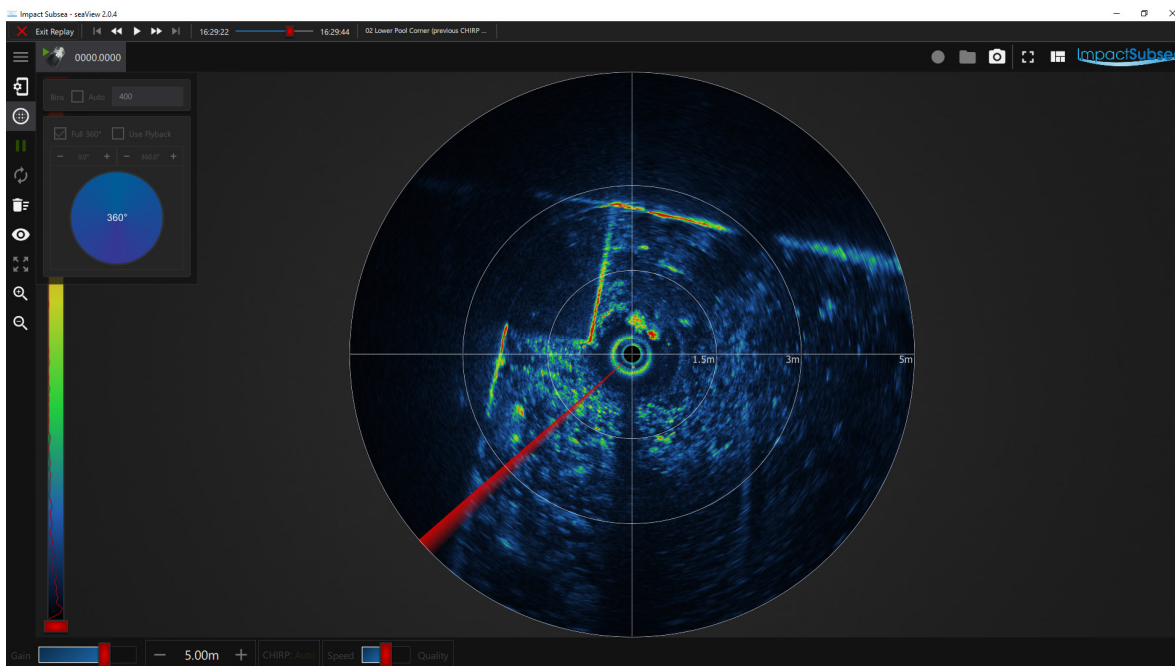

Shown above: ISS360 Setup

Clicking the Setup icon  will allow access to the operational settings of the sonar.

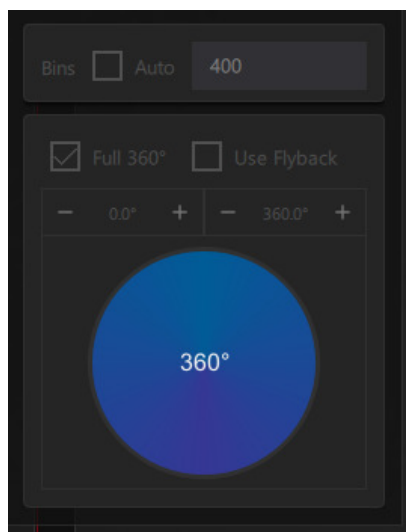

Shown above: ISS360 Setup

In this tab, features such as the scan angle of the sonar (full 360 or user defined sector scan) can be configured.

Flyback can be used to speed up sector scans. Instead of scanning right to left then left to right; in this mode, the sonar will produce imagery one way then quickly flyback to the start position and start again.

**Note:**

Bins are the number of samples that the sonar sends to the seaView software for each 'Ping' that it makes.

When set to 'Auto' seaView will read the number of pixels present on your display screen and request the sonar to send one sample per pixel. This sends the maximum number of values which can physically be shown on screen at any one time.

If operating on a low baud rate serial connection and also using a very high-resolution monitor, you may wish to disable the 'Auto' feature and manually input a lower number of bins. Alternatively, ensure that you move the Speed/Quality bar towards 'Speed' on the regular access controls (see previous page).

This will ensure that the sonar scans quickly and no latency is introduced.

Elements of the sonar display can be enabled or disabled (such as the pitch/roll, image smoothing etc) by clicking the Display Options icon .

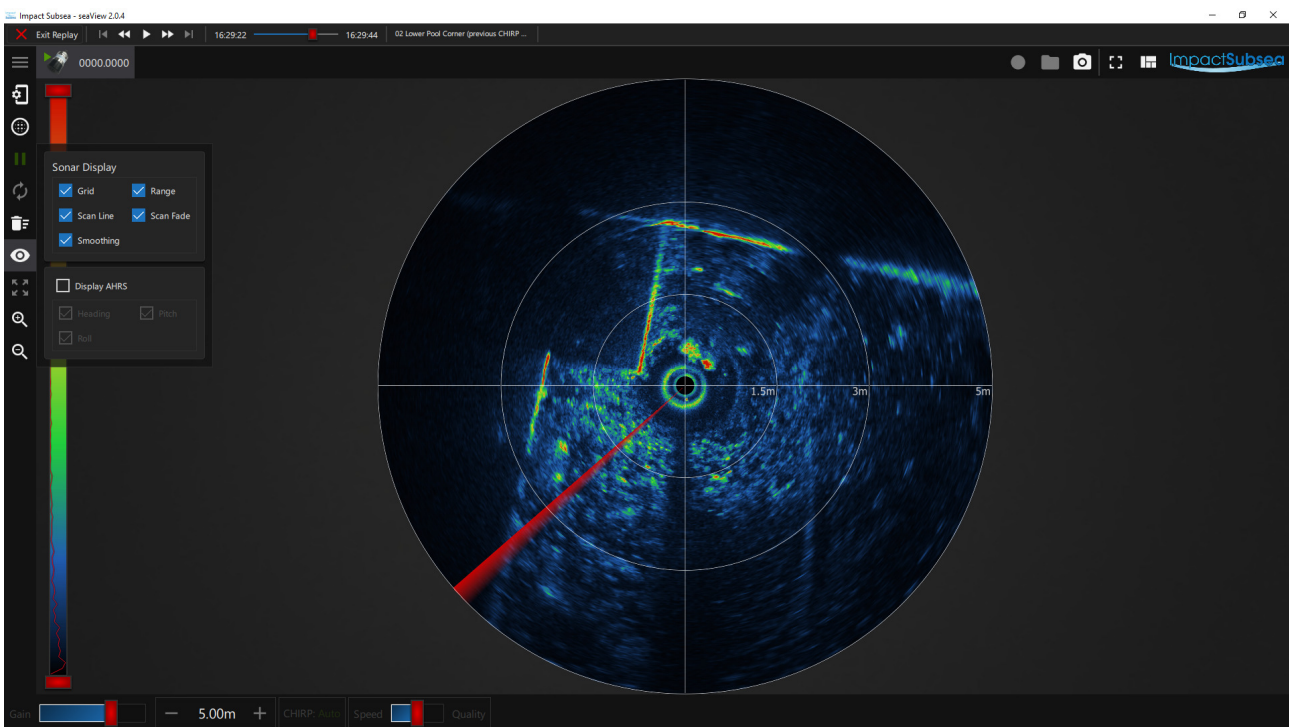

*Shown above: ISS360 Display Options*

## 5.1.4 ISS360 Sensor Settings

Clicking on the settings  icon will allow configuration of the core settings of the sonar.

These settings are divided into three pages: Connection, Orientation and Acoustics.

### Connection:

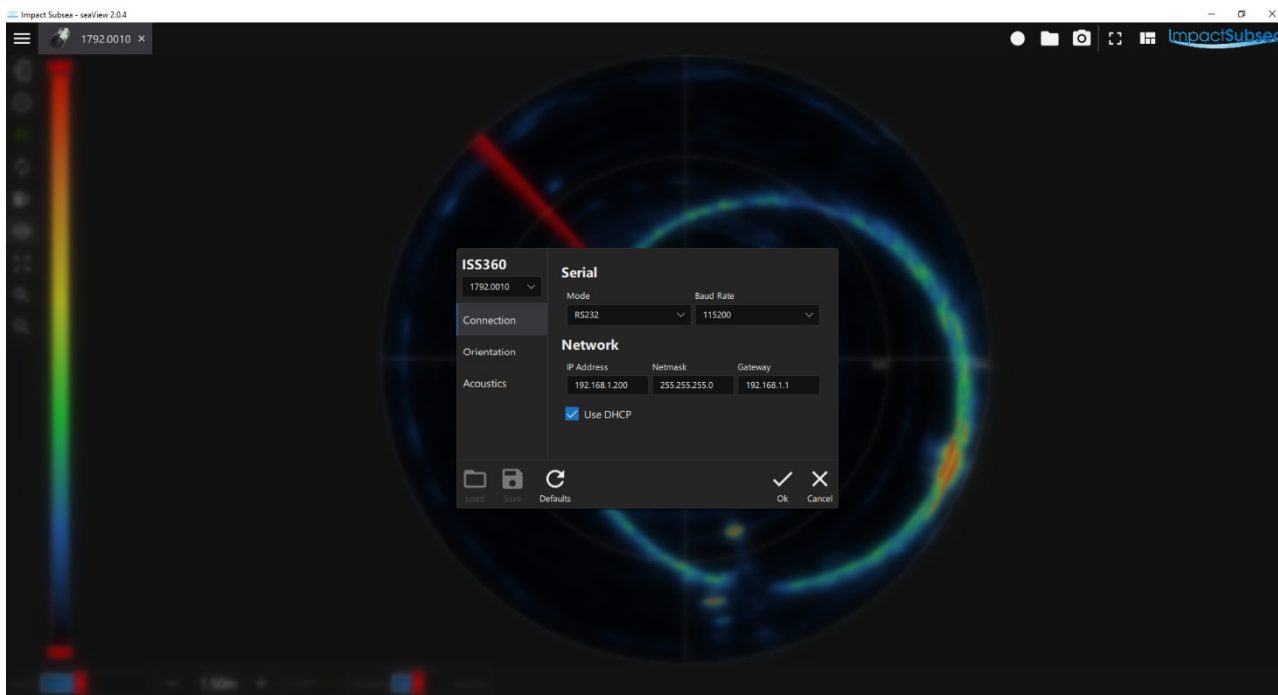

*Shown above: ISS360 Connection Settings*

In this window the serial mode of the sonar (RS232 or RS485) can be configured along with the desired baud rate.

The Network configuration of the sonar can also be configured here.

Once configured, clicking the OK tick button will save the settings to the sonar firmware.

## Orientation & Magnetic Calibration:

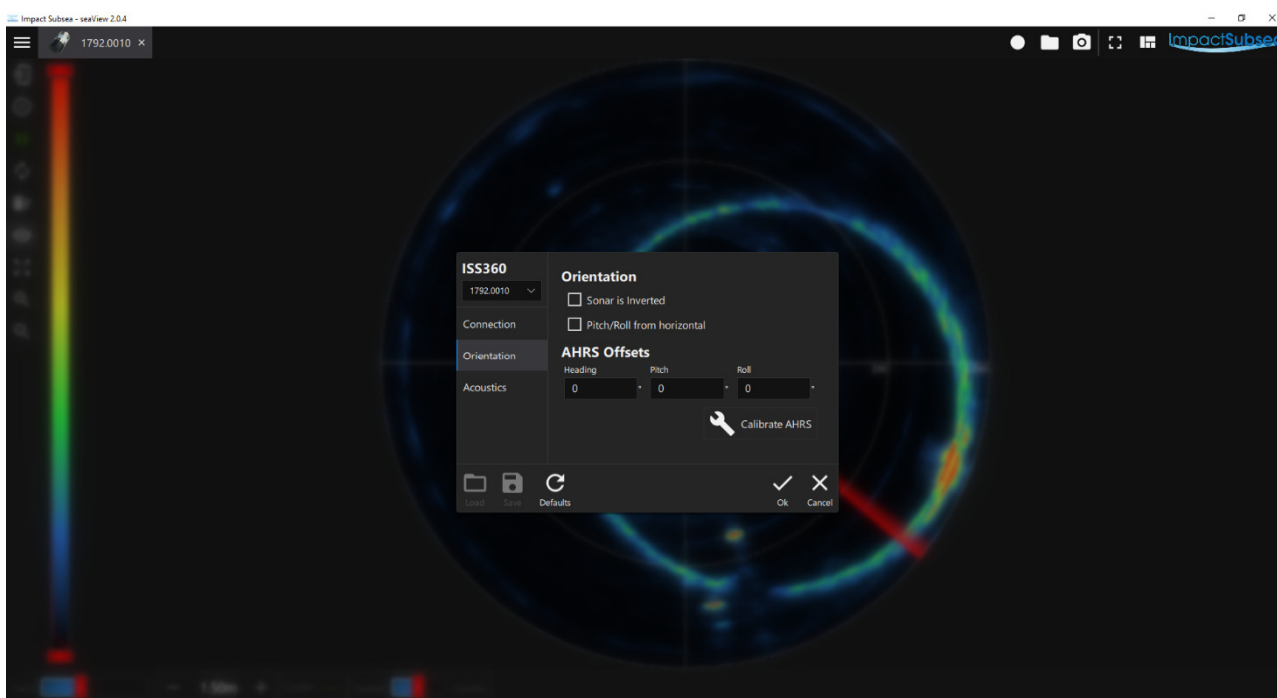

Shown above: ISS360 Orientation Settings

In this window the orientation of the sonar can be defined.

**Note:**

It is standard to have the boot end of the sonar orientated upwards (with the connector downwards). If the boot end of the sonar is facing downwards (with the connector upwards) this is considered to be inverted – in which case the ‘*Sonar is Inverted*’ box should be checked.

If the sonar is installed on its side, the ‘*Pitch/Roll from horizontal*’ box should be checked.

If the optional Pitch & Roll is installed, offsets can be entered here.

Once configured, clicking the OK tick button will save the settings to the sonar firmware.

## Acoustics:

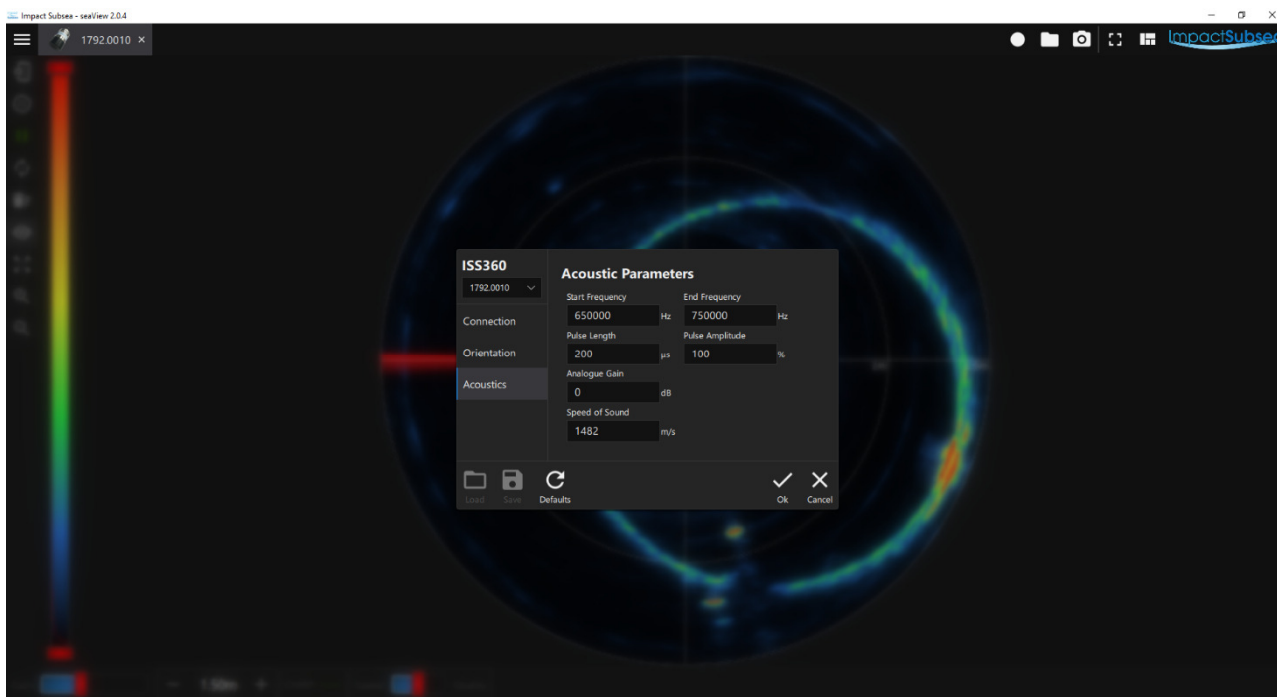

*Shown above: ISS360 Acoustic Parameters Settings*

In the above window, the acoustic settings of the sonar can be adjusted.

It is recommended that these settings are only adjusted by a user with a high degree of experience with the ISS360 or if advised by an Impact Subsea Engineer.

The default settings will provide optimal performance in the majority of applications.



The one value on this page which will require to be adjusted for new location deployments is the speed of sound setting. An accurate speed of sound should be entered to ensure that all range readings are correct.

Once configured, clicking the OK tick button will save the settings to the sonar firmware.

## 5.1.6 Other Settings & Logging

On the left-hand side are further controls for the sonar:





The functions of the Settings  and Setup  buttons have been covered previously in this manual.



The Run/Pause button  will stop the sonar scanning. Pressing again will resume scanning.

The Scan Direction button  will change the direction which the sonar scans (clockwise or counter-clockwise).

The Clear Image button  will erase all sonar image data currently on the display, providing a blank sonar screen.

The Display Options button  has been covered previously in this manual.

The Reset View  button will restore the sonar display to full screen. This is useful if you want to quickly zoom out of a zoomed area of the sonar display.

The Zoom In  and Zoom Out  buttons allow sections of the sonar display to be magnified. Once zoomed in, clicking and holding the left mouse button will allow the area of zoom to be moved around the display. The display can also be zoomed into or out of by using the mouse wheel or by pinching the screen if using a touchscreen display.

Along the top right the following icons are present:



The Record Log button  will allow you to configure and start a log file of the sonar data. The

Open Log button  will allow previously logged data to be played back.

The screenshot button  will save a screengrab of the application.

The Full Screen button  will put the application into full screen mode.

The View Layout button  will allow multiple sonars to be displayed on screen at the same time, instead of having individual tabs for each sonar:

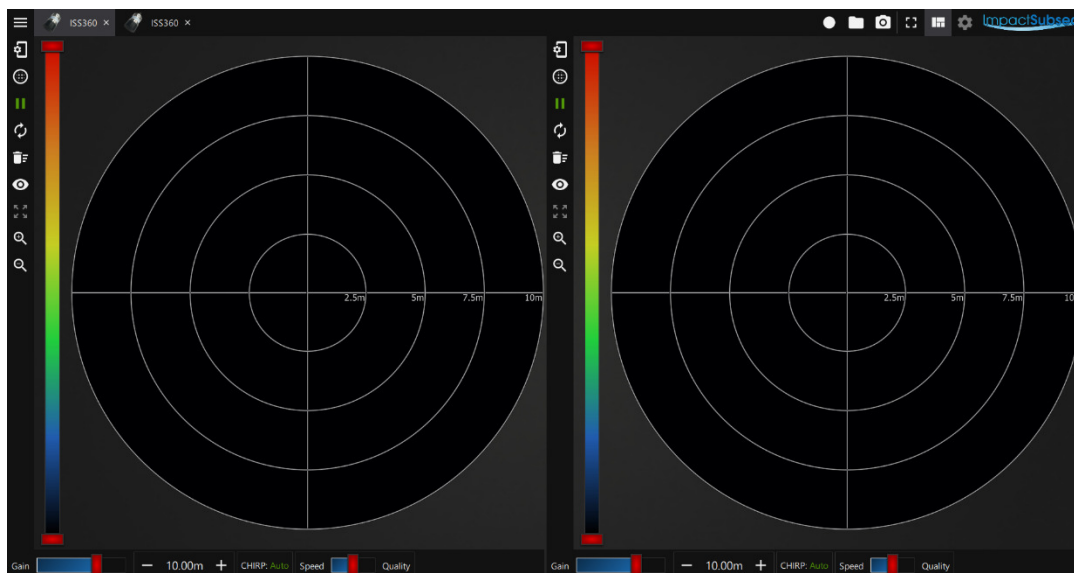

*Shown above: Two ISS360 Sonar displays*

Clicking on the Impact Subsea logo will take you to the Impact Subsea website – ideal for downloading the latest version of the seaView software or accessing other technical information.

## 5.1.7 Hot Keys

### Full Screen:

Pressing the F11 key will activate full screen mode in seaView. Pressing again will deactivate – this can be useful to ensure you maximise the screen space available for the sonar display.



## 6.0 Maintenance & Servicing

The ISS360 & ISS360HD are highly robust Sonars which have been designed to require minimal maintenance. Due to this there are no user serviceable components.

Following use, the sonar should be rinsed in fresh water to remove particles and salt deposits. If required a light detergent (such as that used to clean household dishes) can be used.

### **DO NOT USE SOLVENTS TO CLEAN THE UNIT**

Following rinsing, the sonar should be dried with a cloth.

The connector should be cleaned and a light coating of Molykote 44 Medium grease should be applied.

The sonar should be stored in its original case, in a cool, dry place.

It is recommended that the sonar be returned to Impact Subsea Ltd, on an annual basis to have a 'health check' and service conducted.

## 7.0 Theory of Operation

### 7.1 Sonar – Basic Principles

The ISS360 & ISS360HD are mechanically scanning imaging SONARs (SOund NAVigation and Ranging).

This is an active sonar which operates by transmitting a pulse of sound into the water; then listening for and plotting the returned echoes that are reflected by items in the water.

The ISS360 sonar emits a pulse of sound which is 23° high and 2.2° wide. The ISS360HD sonar emits a pulse of sound which is 30° high and 1° wide. Any item which falls within this pulse of sound will be detected and plotted on screen.

The sonar image is built up by rotating a transducer in the boot end. The transducer emits a pulse of sound (a 'Ping') and listens for any returning echoes across the defined measurement range. Once complete, the transducer is rotated by a step (size defined in the software) and the process repeats.

Through the 'Ping', 'Listen', 'Step' processes: a 2D, top down image is produced on screen.

There are a number of books and resources available online which explore sonar image interpretation in detail. It is assumed the user of the ISS360 or ISS360HD is familiar with basic sonar image interpretation, so detail is not provided here.

Acoustics (also known as hydro-acoustics, or sound pressure waves) are used by the ISS360 & ISS360HD Sonars due to their high efficiency in travelling long distances through water. Through-water acoustics can travel far greater distances than signals in the light or radio frequency spectrum. Thus, are the ideal method to use for visualising the underwater environment.

The Sonar operates by emitting an acoustic pulse into the water. This pulse travels through the water until it comes into contact with the seabed or other objects. Upon contact with the seabed/objects, part of the pulse is absorbed, and part is reflected back to the Sonar.

This reflected portion is detected by the Sonar and the time taken for this acoustic pulse to travel from the Sonar, bounce off the seabed and return is recorded.

The distance the acoustic pulse has travelled can then be calculated by this simple equation:

$$\textit{Distance} = \textit{Speed} \times \textit{Time}$$

In water, the speed of sound is typically around 1,500 meters per second. This is influenced by various factors (temperature, salinity & pressure). However, for the purpose of this explanation, we will assume a speed of sound of 1,500m/s.

If an acoustic pulse takes 0.1 second to return to the ISS360 sonar after being sent, we can calculate its round-trip travel distance as:

$$\begin{aligned}\textit{Distance} &= \textit{Speed} \times \textit{Time} \\ &= 1,500 \times 0.1 \\ &= 150\text{m}\end{aligned}$$

Therefore, the total distance the sound has travelled is 150m (journey to the object + journey back from the seabed).

To calculate the distance, we simply half this value. I.E. the range to target is 75m.

The target would then be plotted on screen at a range of 75 meters.

## 7.2 The Sonar Equation

Any equipment which relies on underwater acoustics for ranging purposes falls into the category of a Sonar, hence the operation is governed by the 'Sonar Equation'.

A clear understanding of this Equation is essential in the design of any acoustic equipment, and is useful for those wishing to utilise acoustic equipment to its full potential.

The Sonar Equation is a fundamental equation, which is at the heart of all hydro-acoustic systems:

$$SL - TL - (NL - DI) > DT$$

**SL** = Source Level

**TL** = Transmission Loss

**NL** = Noise Level

**DI** = Directional Index

**DT** = Detection Threshold

### 7.2.1 Source Level (SL)

The Source level is the power at which the acoustic pulse is put into the water. A greater source level will increase the range capability; however, it will also increase the power consumption.

Therefore, a trade-off between power consumption of the device and the range required must be achieved.

There is also a physical limit to the Source Level; which can be achieved underwater before cavitation occurs, and acoustic transmission breaks down.

## 7.2.2 Transmission Loss (TL)

As the acoustic pulse propagates through the water, it experiences spreading. This causes the energy of the signal to be dispersed over an ever-increasing area, diminishing the energy at any specific point as distance increases.

The acoustic pulse will also experience absorption by the water. The rate at which the acoustic pulse is absorbed is directly related to the pulse frequency. The higher the frequency, the higher the absorption rate.

However, typically the higher the frequency, the higher the acoustic resolution can be achieved. Thus, another trade-off must be made: to use the highest frequency possible, while achieving the desired range capability.

## 7.2.3 Noise Level (NL)

Noise level is environment specific; which can often be the reason for acoustic systems experiencing different levels of performance in different locations, or even when operating at different times.

There are numerous sources that contribute to the background noise level underwater. All of which make the detection of the return acoustic signal increasingly more difficult.

From an environmental perspective, marine life such as snapping shrimp can cause a reasonable level of noise. Also, wind and rain can be a factor if operating close to the water surface.

Man-made sources of noise include those from machinery – such as vessel noise (thrusters and props), and also noise from ROVs and AUVs.

Multipath effects can also add to the background noise. If operating acoustic equipment in an enclosed area/close to a structure, the acoustic signals tend to 'bounce around' which can cause sporadic operation of acoustic equipment.

In the case of imaging sonar, multipath can sometimes cause faint mirrored images of targets.

## 7.2.4 Directional Index (DI)

The Directional Index gives a reduction in noise level, governed by the properties of the transmit/receive transducer.

An omni-directional transducer will theoretically pick-up noise from all directions. A directional transducer will hear noise from only one direction. Thus, a method of reducing the apparent background noise is to utilise a highly directional transducer.

The ISS360 sonar utilises a 23° fan beam which is 2.2° wide. Meaning that any potential interference effects, which exist outside of this beam, will not have a negative impact on the operation of the unit.

## 7.2.5 Detection Threshold (DT)

The Detection Threshold is a property of the acoustic system. It is defined as the minimal signal to noise ratio required in order to detect the acoustic signal.

The threshold can be lowered by minimising the device self-generated noise: utilising advanced acoustic signalling, whilst having a highly capable matching filter or a highly sensitive transducer on the receive side to detect the signal.

The ISS360 Sonar utilises a proprietary acoustic correlator to detect the returning acoustic signal, low noise digital electronics and a highly sensitive composite transducer to enable it to detect extremely small acoustic signals.

An appreciation of the Sonar equation will provide an understanding of the fundamental operation of the ISS360 Sonar. It may help during installation and fault-finding, as it provides an indication to influential factors.

## 8.0 Warranty

The ISS360 & ISS360HD Sonar is supplied with a Limited Warranty. This warranty applies solely to the ISS360 & ISS360HD Sonar and only if purchased directly from Impact Subsea Ltd.

### **What does the limited warranty cover?**

This Limited Warranty covers any defects in material or workmanship under normal use during the Warranty Period.

During the Warranty Period, Impact Subsea Ltd will repair or replace products, or part of a product (under normal use and maintenance), that prove defective due to improper material or workmanship.

### **What will we do to correct the problems?**

Impact Subsea Ltd will either replace or repair the Product at no charge: using new or refurbished replacement parts. Replacement or repair is at the discretion of Impact Subsea Ltd.

### **How long does the coverage last?**

The Warranty Period for the ISS360 or ISS360HD Sonar, purchased from Impact Subsea Ltd, is 1 year from the date of dispatch from Impact Subsea Ltd.

A replacement ISS360 or ISS360HD, or part, assumes the remaining warranty of the original Sonar or 60 days from the replacement/repair, whichever is longer.

### **What does this limited warranty not cover?**

This limited warranty does not cover any problem that is caused by conditions, malfunctions or damage resulting from defects in material or workmanship.

### **What do you have to do?**

To obtain a warranty repair of your ISS360 Sonar, you must first contact Impact Subsea Support to determine the problem and the most appropriate solution for you.



## 9.0 Technical Support

Should you require technical support for your ISS360 Sonar, our Support team can be contacted as follows:

- T.** +44 (0) 1224 460 850
- E.** [support@impactsubsea.co.uk](mailto:support@impactsubsea.co.uk)
- W.** [www.impactsubsea.com](http://www.impactsubsea.com)

An out of hours emergency number is available via the Impact Subsea website.

Utilising the above email address will ensure that a number of support engineers are copied into your support request, and will ensure a prompt response.

When contacting our Support team, please provide the following details of the ISS360 Sonar:

- Serial Number
- Firmware version
- Software version
- Fault Description
- Remedial action undertaken thus far

Every effort is made to ensure that information within this document is up to date. However, information within this document is subject to change without notice, in-line with our commitment to continuous product development and improvement.