

ISM3D

Heading, Pitch & Roll Sensor



Installation & Operation Manual

Revision Number:	1.4
Date	23 rd April 2020

1.0 Introduction	2
2.0 Specification	3
2.1 ISM3D Overview	3
2.2 ISM3D Dimensions	3
2.3 Attitude & Heading Reference System	4
2.4 Communications, Power & Physical	4
3.0 Overview	5
4.0 Installation	6
4.1 Location	6
4.1.1 Magnetic Disturbers (For Heading Accuracy)	6
4.1.2 Alignment with Vehicle (For Pitch/Roll Accuracy)	6
4.2 Mounting	7
4.3 Electrical	8
4.3.1 Connector Pin Out	8
4.3.2 Power	9
4.3.3 Serial Interface	9
4.3.4 RS232 Wiring	9
4.3.5 RS485 Wiring	9
4.3.6 Establishing Communications	10
4.3.7 Connector Mating	10
4.3.8 Connector Cleaning	10
5.0 Operation	11
5.1 Use With seaView Software	11
5.2 Integration With Systems	12
5.3 ISM3D Setup	12
5.4 Magnetic Calibration	14
6.0 ASCII Output Strings	19
6.1 AHRS	19
7.0 Servicing	23
8.0 Warranty	24
9.0 Technical Support	25

Every effort is made to ensure that information within this document is up to date. However, information within this document is subject to change without notice, in-line with our commitment to continuous product development and improvement.

1.0 Introduction

The ISM3D sensor is a compact and highly accurate Attitude and Heading Reference System providing Heading, Pitch & Roll.

Suitable for a large range of underwater applications, the ISM3D can be used with ROVs, AUVs, Hydro-graphic Survey, Construction, Positioning and any other application where accurate Heading, Pitch & Roll is required underwater.

The Heading, Pitch and Roll readings are provided from integrated Micro Electro Mechanical Systems (MEMS) based Magnetometers, Accelerometers and Gyroscopes. The outputs of each MEMS based device are fused together to provide highly accurate and stable Heading, Pitch and Roll measurements.

With a unique Inertial Heading mode, the ISM3D provides high resilience against temporary magnetic interferers. This enables successful prolonged operation alongside steel structures where required.

Housed in a compact and lightweight Titanium or Acetal housing ensures that the ISM3D is not only at the forefront of sensor technology; but is built to withstand the most extreme underwater environments.



ISM3D Attitude & Heading Reference System (Titanium)

2.0 Specification

2.1 ISM3D Overview

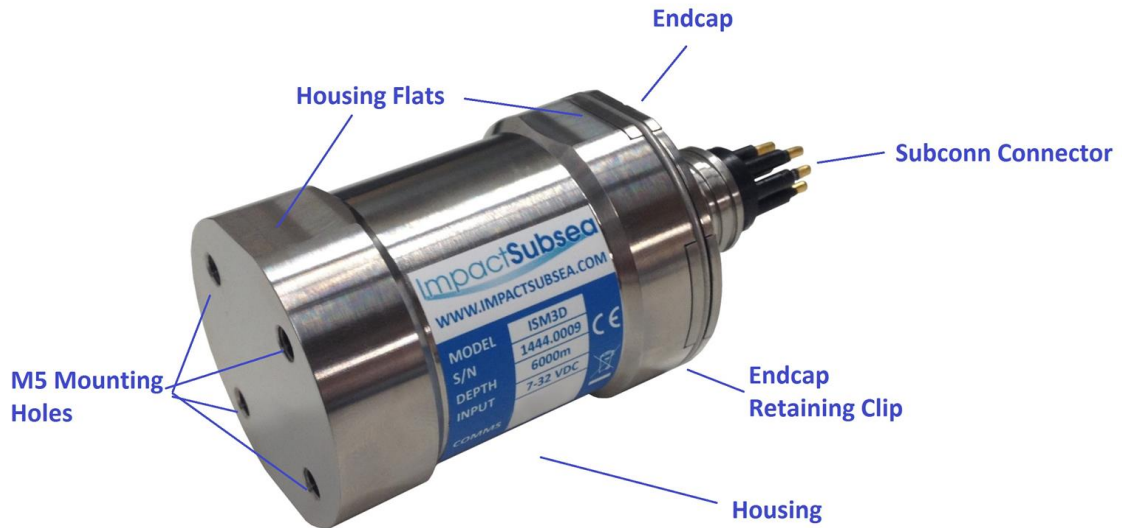

2.2 ISM3D Dimensions

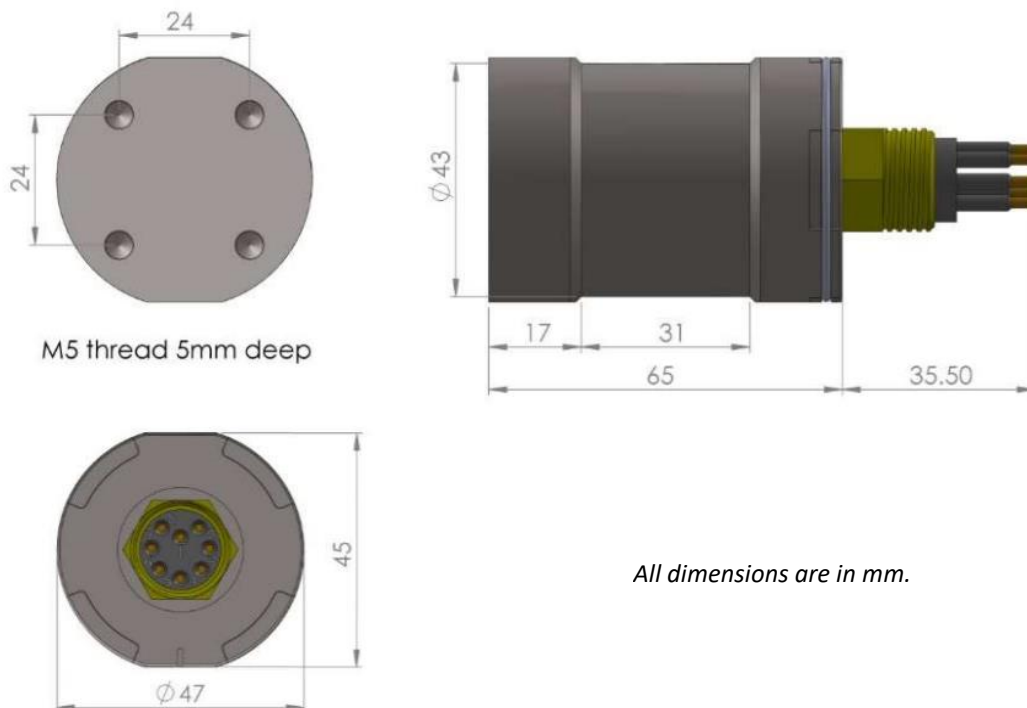

All dimensions are in mm.

2.3 Attitude & Heading Reference System

Heading		Attitude	
Accuracy	± 0.5° of Magnetic North	Pitch	± 90°
		Roll	± 180°
Resolution	0.01°	Accuracy	± 0.07°
		Resolution	0.01°

2.4 Communications, Power & Physical

Communications & Power		Physical	
Digital	RS232 & RS485	Weight (Air/Water)	Titanium: 0.33/ 0.225kg Acetal: 0.20 / 0.10kg
Protocol	300 to 115,200 baud	Depth Rating	Titanium: 6,000 meters Acetal: 1,000 meters
Data	Continuous or on demand	Temperature	Operating: -10 to 50° Storage: -20 to 70°
Data Rate	Up to 250Hz	Connector	Subconn MCBH8M-SS fitted as standard
Input Voltage	7 to 32V DC		
Power	29mA @ 24V DC		

3.0 Overview

The ISM3D is a highly compact, robust and accurate underwater Attitude & Heading Reference System (AHRS).

The ISM3D is depth rated to 1,000 meters (Acetal) or 6,000 meters (Titanium).

The Heading, Pitch and Roll readings are provided by a Micro-Electro-Mechanical system (MEMS) based technology. MEMs based Gyros, Accelerometers and Magnetometers are integrated within the unit.

The outputs from each MEMS based sensor are processed by an advanced fusion algorithm to provide highly stable and accurate Heading, Pitch & Roll.

For optimal heading performance, a hard and soft iron calibration can be performed on the unit once installed on the ROV, AUV or another underwater platform. This ensures that a consistently accurate heading is provided at all times.

In areas where a large amount of steel or other magnetic disturber is present, the unit can be switched to Inertial mode. Inertial mode operates using the Angular Rate Gyroscopes and Accelerometers, without input from the Magnetometer. The low drift rate of the MEMS based Gyroscopes enables navigation to be conducted in areas where previously only a fibre or ring laser diode based heading sensor would suffice.

The ISM3D can be configured using the supplied seaView software. seaView allows all settings to be configured (output strings, communications protocol, baud rate etc).

In addition to allowing the ISM3D to be configured, seaView also allows all outputs to be viewed in real time and logged.

4.0 Installation

4.1 Location

When evaluating the installation location of the ISM3D, there are several factors to consider to achieve optimum operation from each part of the unit:

- **Magnetic Disturbers** (Heading)
- **Alignment with Vehicle** (Pitch/Roll)

4.1.1 Magnetic Disturbers (For Heading Accuracy)

Where the heading output is to be used, the ISM3D should be mounted as far as possible from sources of magnetic interference.

Electrical items which can cause magnetic interference include motors, transformers and valve packs.

Ferrous metals, or any other magnetically active materials will also have influence on the heading reading. Thus, where possible, the unit should be installed as far as possible from magnetically active materials.

A magnetic calibration should be conducted using the seaView software once the unit is physically installed.

4.1.2 Alignment with Vehicle (For Pitch/Roll Accuracy)

When mounting **vertically**, the ISM3D should be mounted with the base (complete with mounting screw holes) facing downwards (to the seabed) and the indentation in the connector end cap pointing forwards, in the direction of forward vehicle travel:

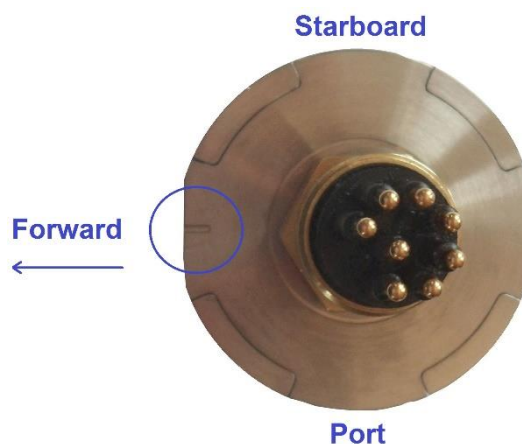

When mounting **horizontally** the ISM3D should be installed with the indentation in the connector end cap pointing upwards:



4.2 Mounting

The ISM3D should be mounted using four M5 Screws, screwed into the base of the unit:

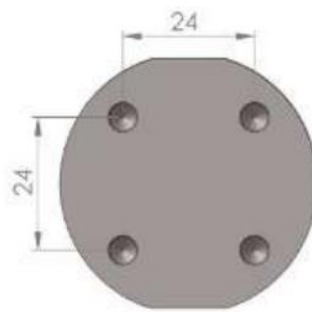

M5 thread 5mm deep

Alternatively, the unit has a 31mm recess in the main body to enable a clamp to be tightened securely around the unit:



Ideally a non-metallic clamp should be used, however in the event that this is not possible, effort should be made to electrically isolate the clamp from the ISM3D housing. This can be achieved by using rubber or plastic strips around the body of the ISM3D.

The ISM3D has two flats, on either side of the body – these are to enable the unit to sit tightly against another flat surface if available.

4.3 Electrical

The ISM3D is fitted with a SubConn MCBH8M-SS connector as standard. This will mate to a SubConn MCIL8F connector/cable assembly.

4.3.1 Connector Pin Out

The standard connector pin out is provided below:

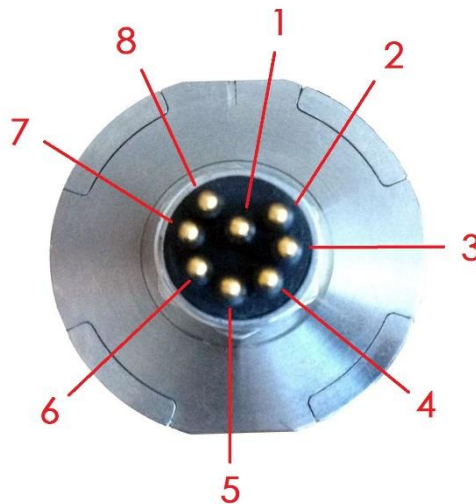

Male Connector on ISM3D Unit

Pin	Function	Mating Wire Colour
1	0VDC	Black
2	7-32VDC	White
3	Not Used	Red
4	Not Used	Green
5	0V Digital	Orange
6	Not Used	Blue
7	RS232 TX & RS485 A+	White/Black
8	RS232 RX & RS485 B-	Red/Black

4.3.2 Power

The ISM3D is polarity protected and fused with a 400mA resettable poly fuse. Internal circuitry isolates the supply from the outside environment requiring the serial interface to use the digital 0V reference pin.

4.3.3 Serial Interface

The RS232 and RS485 interface is isolated from the supply and has in-line fused protection on the serial lines. A prolonged transient voltage on these lines will blow the surface mount fuses which will require replacement by Impact Subsea or an approved distributor.

4.3.4 RS232 Wiring

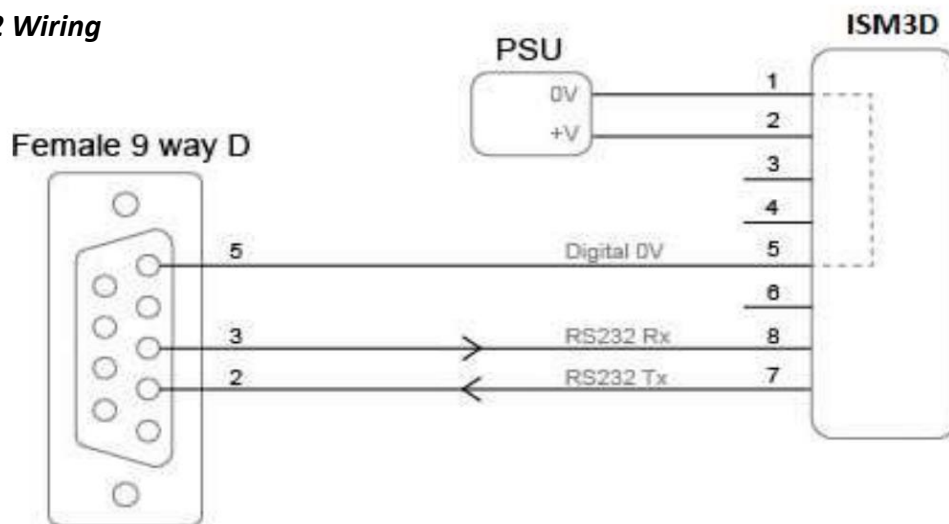

4.3.5 RS485 Wiring

The RS485 termination resistor is software selectable.

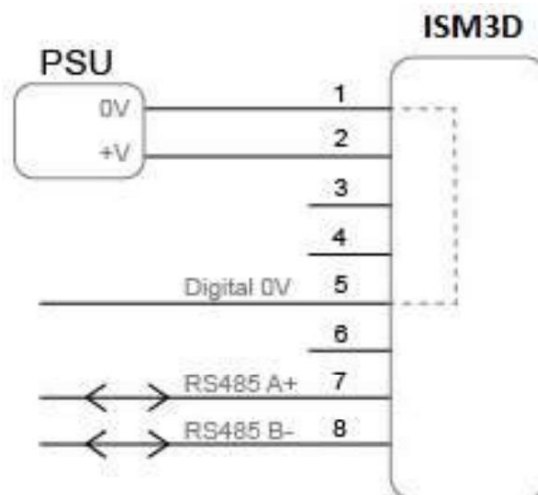

The digital 0V must be connected on an RS485 interfaces, otherwise the voltage potential between one of the A+ or B- lines to ground could reach a damaging level.

4.3.6 Establishing Communications

The default serial settings are **RS232, 9600, N81**

If the ISM3D is tilted from vertical to upside down 3 times within the first 10 seconds of power up then it will temporarily configure the serial interface to the default and output an ASCII message with the settings.

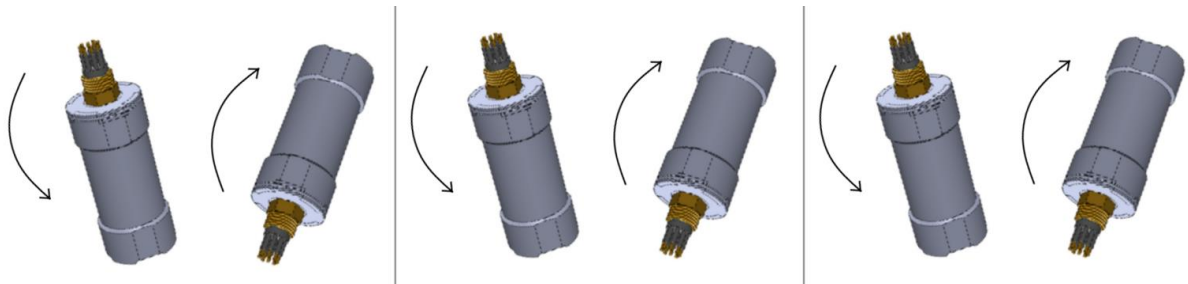

Note: When the device is powered cycled the serial interface setting will revert back to the last configuration.

4.3.7 Connector Mating

When mating the cable to the SubConn connector, to maximise the life of the connector, it is important to observe the following:

- Always apply grease before mating. Molykote 44 Medium grease must be used.
- Disconnect by pulling straight, not at an angle.
- Do not pull on the cable and avoid sharp bends at cable entry.
- Do not over-tighten the bulkhead nut.

Do not expose the connector to extended periods of heat or direct sunlight. If a connector becomes very dry, it should be soaked in fresh water before use.

4.3.8 Connector Cleaning

General cleaning and removal of any accumulated sand or mud on a connector should be performed using spray based cleaner (for example Isopropyl Alcohol).

New grease must be applied again prior to mating.

5.0 Operation

5.1 Use With seaView Software

The ISM3D is supplied with the highly intuitive seaView software.

The latest version of seaView can be downloaded from: www.impactsubsea.com.

seaView can be used with all Impact Subsea sensors. Single sensors can be operated, or multiple sensors together.

seaView is designed for use with a PC running the Windows 7, 8 or 10 operating system and requires Microsoft's .net framework 4.5.2 or above to be installed.

seaView uses an advance framed binary protocol to communicate to the ISM3D and can do so over RS232 or RS485 at any standard baud rate.

The parity must be none, stop bits 1 and data bits 8. If the ISM3D communication settings differ from this then perform the comms reset as described in the 'Establishing Communications' section of this manual.

All settings and offsets are saved to the ISM3D device flash memory.

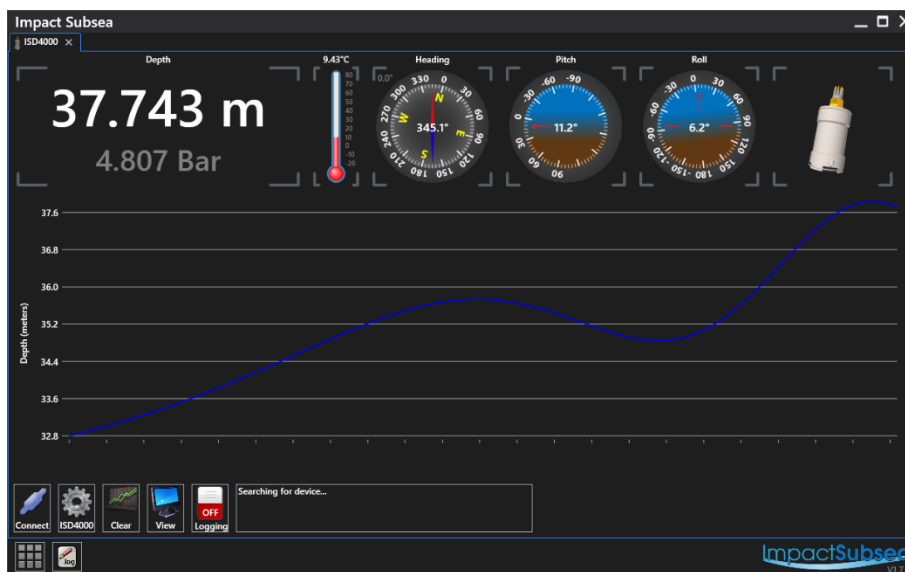

Impact Subsea seaView Software

5.2 Integration With Systems

Conceptually there are two modes of operation, Interrogated and Autonomous:

Interrogation mode requires a master to request the ISM3D to make a measurement and report this back.

The ISM3D can be interrogated by the user defined interrogation string. Upon interrogation the ISM3D will make a measurement and report back the result over the serial interface.

Autonomous mode will make a measurement and output the results at a specified time interval.

The ISM3D can be configured to operate in one or both of these modes at the same time.

5.3 ISM3D Setup

The ISM3D unit can be configured to output a variety of output strings, at various output rates, autonomously or by interrogation.

Offsets can be applied to the Heading, Pitch & Roll, the reference point for Pitch, Roll & Heading can be changed and Inertial Mode can be enabled and disabled.

All settings can be viewed and adjusted by using the Impact Subsea seaView software. To alter settings, the ISM3D application should be run and the settings page opened.

Clicking the green tick 'Save' button at any time will save the configured settings to the ISM3D firmware. These settings will then be held until the ISM3D is next configured using the seaView software.

5.3.1 Communication Protocol

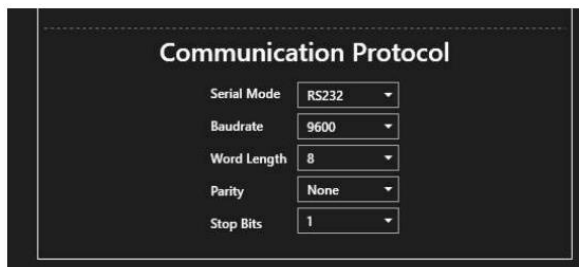

Communication Protocol	
Serial Mode	RS232
Baudrate	9600
Word Length	8
Parity	None
Stop Bits	1

The Serial Mode can be adjusted (RS232, RS485 or RS458 Terminated).

The baud rate, word length, parity and stop bits can also be adjusted to suit interface requirements.

5.3.2 ISM3D Setup

The second setup page allows configuration of the output string, which mode the ISM3D should work in along with various offsets:

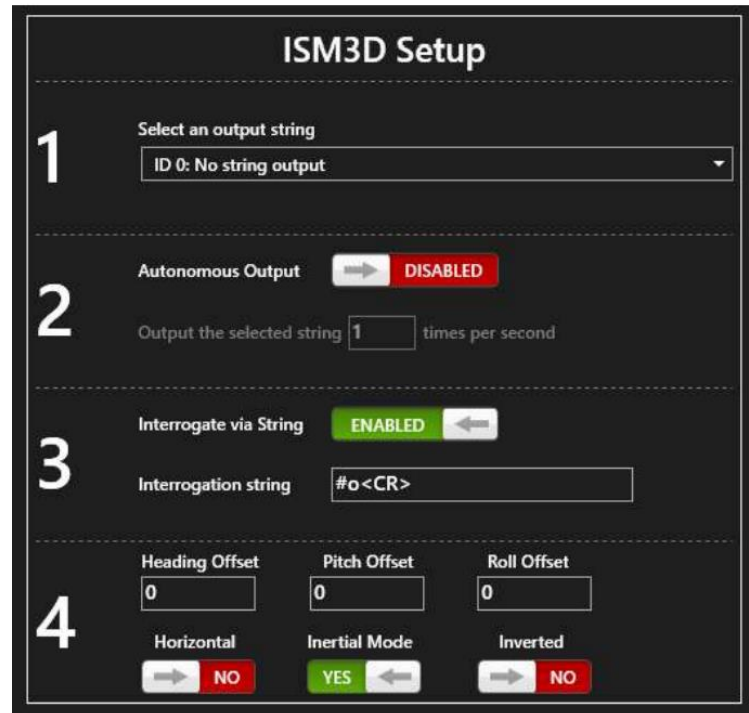

The settings on each line (1 to 4) shown above are detailed:

Line 1:

Allows for the selection of the required output string:

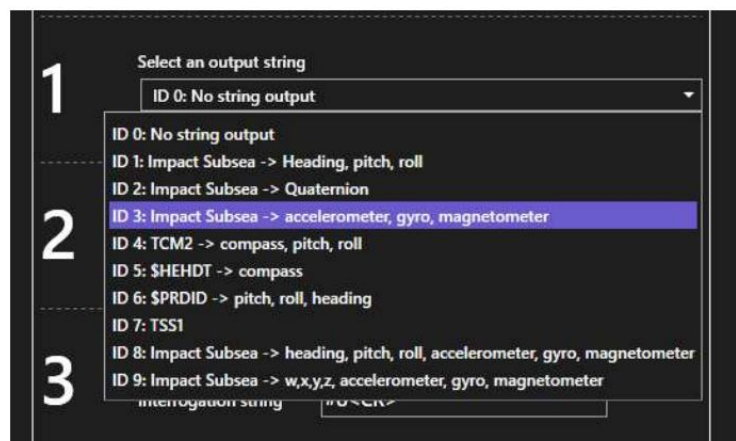

Line 2:

Allows autonomous mode to be enabled and disabled. When enabled, the rate at which the output string (defined in line 1) is set in times per second (Hz).

Line 3

Allows for an interrogation string to be enabled and disabled. When enabled the interrogation string (which is used to trigger the output defined in line 1) can be configured to a command of the users choice. If this is not altered, the default trigger command is #o<CR>.

Line 4

Allows an offset to be applied to the Heading, Pitch & Roll. If the difference between magnetic north and true north is known, the offset can be applied here (either positive or negative degrees). This will enable the ISM3D to report True North heading values.

Any inaccuracy in mounting (causing an offset to the pitch & roll) can be zero'd using the Pitch and Roll offsets.

If the unit has been mounted Horizontally or Inverted, this can be set in the buttons of Line 4.

Line 4 also allows the Inertial Mode of the ISM3D to be enabled or disabled. The default and recommended setting is to have the inertial mode enabled.

When **inertial mode** is enabled, the magnetometers are only used for the first ten seconds after power up to find magnetic north. After ten seconds, the high grade MEMS Gyros take over as the primary heading device and update the heading accordingly. In this mode the unit is highly resilient to magnetic interference and can operate alongside sources of magnetic interference for several hours without significant drift in the heading.

5.4 Magnetic Calibration

Following final physical installation on the vehicle (or other structure) it is critical that a magnetic calibration is conducted.

The magnetic calibration takes into account all local hard and soft iron artefacts of the vehicle (or other structure the ISM3D is mounted to). This enables the correction of any heading offsets that permanent magnetic interferers may cause.

If the magnetic calibration is not conducted, the heading will not be correct and will suffer from non-linear movement when rotated. For example when operating with inertial mode disabled, a 90° physical rotation may only be recognised as a 80° rotation.

To conduct a good magnetic calibration, please complete the following procedure. There is also a video demonstration of this procedure available on the ISM3D product page of the Impact Subsea website.

5.4.1 Magnetic Calibration Procedure

Step 1: Ensure that the ISM3D has been physically installed in a location as free from magnetic interference as possible (away from valve packs, thrusters etc).

Step 2: Check that the ISM3D is mounted securely to the structure ensuring the unit is not able to move independently from the structure.

Step 3: If conducting the magnetic calibration in a workshop, ideally hang the ROV from a crane away from magnetic sources. If conducting the calibration at sea, deploy the ROV and move into open water, away from any structures with a magnetic property (vessel, pipeline etc). **Do not conduct the calibration with the ROV on the vessel.**

Step 4: Run the seaView software, select the ISM3D application and connect to the ISM3D unit:



Step 5: Once connected to the ISM3D, go into the ISM3D settings (Gear Cog graphic):



Step 6: Click on the 'Calibrate' button to open the calibration window:



Step 7: On the 'Mode' button, click this to change it to 'Calibrate'

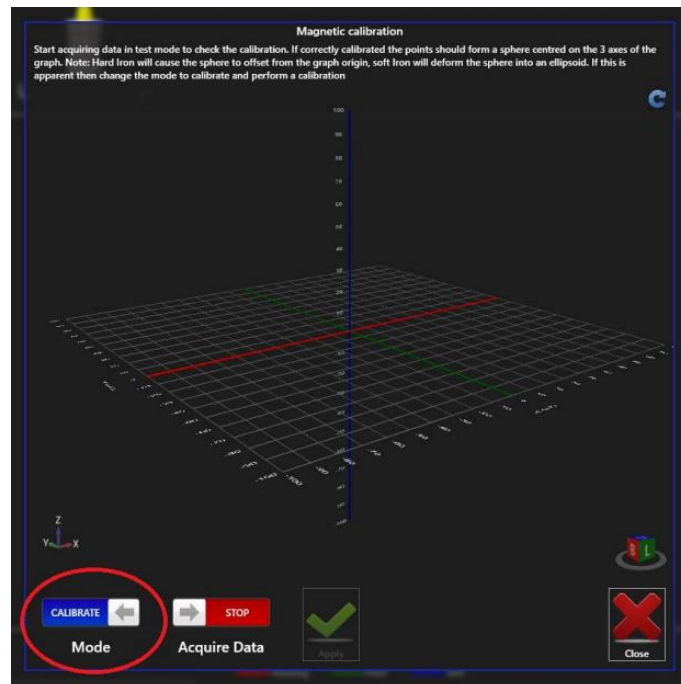

Step 8: On the 'Acquire Data' button change to 'Start'. The calibration process has now begun.



Step 9: Rotate the ROV through 360 degrees.

Step 10: Keep rotating the ROV through 360 degrees and pitch/roll the ROV as much as is possible.

On screen you will see the sides of a ball forming from a number of dots. Click on the ball to rotate and see if there are any gaps in data. Physically move the ROV to fill this data.



Continue this process for five to ten minutes, until a good amount of data points are visible on screen. The ideal calibration will result in a complete 3D ball on screen – this may not be achievable with large ROVs, but effort should be made to get as close to this as possible:

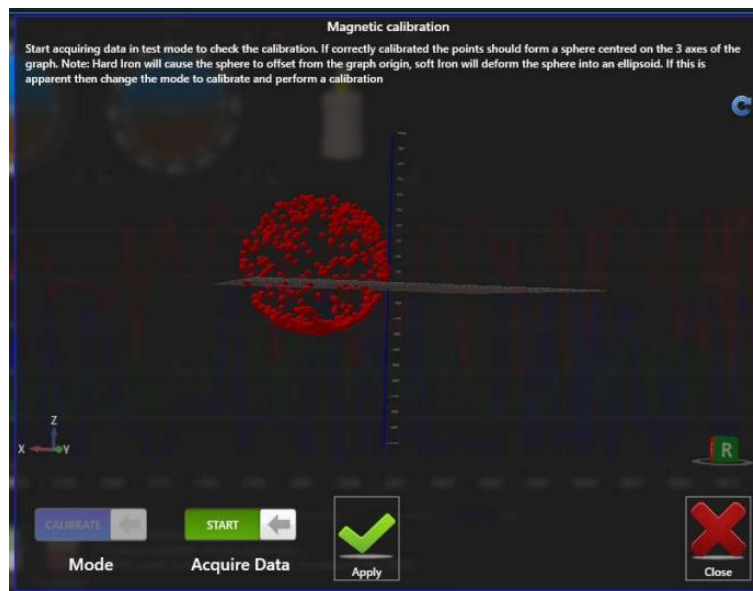

Step 11: Once you have completed the calibration click 'Apply' to save the calibration to the ISM3D unit.



Step 12: Power Cycle the ISM3D unit.

The ISM3D will now point to magnetic north and provide good operation. If this is not the case, the magnetic calibration has not been completed to a sufficiently high standard and will require to be conducted again.

If a good calibration cannot be performed, due to lack of movement or excessive magnetic interference, ensure that the unit is set to operate in inertial mode. Power the unit and allow ten seconds for the heading to stabilise.

Once the heading has stabilised, a Heading Offset can be applied as per section 5.3.2 of this manual. This can be used to correct the heading of the unit to a known true value.

6.0 ASCII Output Strings

6.1 AHRS

ID1: Impact Subsea heading, pitch, roll

String format:

$\$ISHPR,hhh.h,spp.p,srrr.r*xx<CR><LF>$

s = sign + or -

hhh.h = heading in degrees (0 to 359.9)

pp.p = pitch in degrees (90.0 to -90.0)

rrr.r = roll in degrees (180.0 to -180.0)

xx = NMEA standard checksum

ID2: Impact Subsea quaternion

Quaternions represent the orientation of a 3D body in a 4 dimensional world. This avoids the associated gimbal lock / singular problems with conventional heading, pitch, roll.

String format:

$\$ISQUA,w,x,y,z*xx<CR><LF>$

w= floating point number Q0

x = floating point number Q1

y = floating point number Q2

z = floating point number Q3

xx = NMEA standard checksum

ID3: Impact Subsea Accelerometer, Gyro, Magnetometer

String format:

$\$ISAGM,a.aaa,a.aaa,a.aaa,g.ggg,g.ggg,g.ggg,m.mmm,m.mmm,m.mmm*xx<CR><LF>$

a.aaa = Accelerometer reading: X then Y then Z

g.ggg = Gyroscope reading: X then Y then Z

m.mmm = magnetometer reading: X then Y then Z

xx = NMEA standard checksum

All values are floating point numbers. Sign only shown if negative.

Accelerometer data is provided in G

Gyroscope data is provided in degrees per second

Magnetometer data is provided in micro Tesla

ID4: TCM2 compass, pitch, roll

String format:

$\$Chhh.h,Ppp.p,Rrr.r*xx<CR><LF>$

hhh.h = heading in degrees (0 to 359.9)

pp.p = pitch in degrees (90.0 to -90.0)

rr.r = roll in degrees (90.0 to -90.0)

xx = NMEA standard checksum (note: hex character are capital)

ID5: HEHDT compass

String format:

$\$HEHDT,hhh.h,T*xx<CR><LF>$

hhh.h = heading in degrees (0 to 359.9)

xx = NMEA standard checksum (note: hex character are capital)

ID6: PRDID pitch, roll, heading

String format:

$\$PRDID,pp.p,rrr.r,hhh.h*xx<CR><LF>$

pp.p = pitch in degrees (90.0 to -90.0)

rrr.r = roll in degrees (180.0 to -180.0)

hhh.h = heading in degrees (0 to 359.9)

xx = NMEA standard checksum (note: hex character are capital)

ID7: TSS1

String format:

:aaaabbbb 0000U rrrrr ppppp<CR><LF>

aaaa = horizontal acceleration

bbbb = vertical acceleration

rrrrr = roll in degrees * 100 (9000 to -9000)

ppppp = pitch in degrees * 100 (9000 to -9000)

ID8: Impact Subsea heading, pitch, roll, accelerometer, gyro, magnetometer

String format:

*\$ISALL,hhh.h,spp.p,srrr.r,a.aaa,a.aaa,a.aaa,g.ggg,g.ggg,g.ggg,m.mmm,m.mmm,m.mm
m*xx<CR><LF>*

s = sign + or -

hhh.h = heading in degrees (0 to 359.9)

pp.p = pitch in degrees (90.0 to -90.0)

rrr.r = roll in degrees (180.0 to -180.0)

a.aaa = Accelerometer reading: X then Y then Z

g.ggg = Gyroscope reading: X then Y then Z

m.mmm = magnetometer reading: X then Y then Z

xx = NMEA standard checksum

ID9: Impact Subsea w,x,y,z,accelerometer, gyro, magnetometer

String format:

*\$ISQUR,w,x,y,z,a.aaa,a.aaa,a.aaa,g.ggg,g.ggg,g.ggg,m.mmm,m.mmm,m.mmm*xx<CR>
<LF>*

w = floating point number Q0

x = floating point number Q1

y = floating point number Q2

z = floating point number Q3

a.aaa = Accelerometer reading: X then Y then Z

g.ggg = Gyroscope reading: X then Y then Z

m.mmm = magnetometer reading: X then Y then Z

xx = NMEA standard checksum

ID10: Minisense

String format:

`$AHhh.h APpp.p ARrrr.r M9 E18000 S0 C<CR><LF>`

hhh.h = heading in degrees (0 to 359.9)

pp.p = pitch in degrees (90.0 to -90.0)

rrr.r = roll in degrees (180.0 to -180.0)

7.0 Servicing

The ISM3D housing is available in Titanium or Acetal. The unit is intended to be exceptionally low maintenance.

To avoid the build up of salt, the unit should be rinsed in fresh water after each use.

Prior to storage the unit should be thoroughly cleaned and dried.

8.0 Warranty

The ISM3D is supplied with a Limited Warranty. This warranty applies only to the ISM3D unit, and only if the ISM3D is purchased from Impact Subsea Ltd.

What does the limited warranty cover?

This Limited Warranty covers any defects in material or workmanship under normal use during the Warranty Period.

During the Warranty Period, Impact Subsea Ltd will repair or replace, at no charge, products or part of a product that prove defective because of improper material or workmanship under normal use and maintenance.

What will we do to correct the problems?

Impact Subsea Ltd will either replace or repair the Product at no charge, using new or refurbished replacement parts. Replacement or repair is at the discretion of Impact Subsea Ltd.

How long does the coverage last?

The Warranty Period for the ISM3D, purchased from Impact Subsea Ltd, is 1 year from the date of dispatch from Impact Subsea Ltd.

A replacement ISM3D, or part assumes the remaining warranty of the original ISM3D or 60 days from the replacement or repair, whichever is longer.

What does this limited warranty not cover?

This limited warranty does not cover any problem that is caused by conditions, malfunctions or damage not resulting from the defects in material or workmanship.

What do you have to do?

To obtain a warranty repair of your ISM3D unit, you must first contact Impact Subsea Support to determine the problem and the most appropriate solution for you.

9.0 Technical Support

Should you require technical support for your ISM3D unit, our Support team can be contacted as follows:

T. +44 (0) 1224 460 850

E. support@impactsubsea.co.uk

W. www.impactsubsea.com

An out of hours emergency number is available via the Impact Subsea website.

Using the above email address will ensure that multiple engineers are copied into your support request, and will ensure a prompt response.

When contacting our Support team, please provide the following details of the ISM3D:

- Serial Number
- Firmware version
- Software version (if applicable)
- Fault Description
- Remedial action undertaken thus far

Every effort is made to ensure that information within this document is up to date. However, information within this document is subject to change without notice, in-line with our commitment to continuous product development and improvement.