

ISFMD

Flooded Member Detection System



Installation & Operation Manual

Revision Number:	1.2
Date	23 rd April 2020

1.0 Introduction	2
2.0 Specification	3
2.1 Probe Overview	3
2.2 Dimensions	3
2.2.1 Probe:	3
2.2.2 Probe Mount:	4
2.3 Acoustic, Heading, Attitude & Temperature	5
2.4 Communications, Power & Physical	5
3.0 System Components	6
3.1 Probe	6
3.2 Probe Protective Holder	6
3.3 Cable Reel	6
3.4 Topside Interface Box	7
3.5 seaView Software	7
4.0 Hardware Setup	8
4.1 Diver Deployed System	8
4.2 ROV Deployed System	9
4.2.1 Connector Pin Out	9
4.2.2 Power	10
4.2.3 Serial Interface	10
4.2.4 RS232 Wiring	10
4.2.5 RS485 Wiring	11
4.2.6 Establishing Communications	11
5.0 Software Installation	13
6.0 Conducting An FMD Test	14
6.1 Understanding FMD Readings	16
7.0 Servicing	18
8.0 Theory of Operation	19
8.1 Flooded Member Detection - Basic Principles	19
9.0 Common Questions & Answers	21
10.0 Warranty	23
11.0 Technical Support	24

Every effort is made to ensure that information within this document is up to date. However, information within this document is subject to change without notice, in-line with our commitment to continuous product development and improvement.

1.0 Introduction

Suitable for Diver or ROV use the ISFMD system provides the most advanced and reliable acoustic Flooded Member Detection system available today.

Utilising a detection probe with broadband composite transducer technology, together with an advanced digital acoustic engine ensures the highest level of accuracy and reliability in readings.

All readings are shown visually in the supplied seaView software package. Each reading is accompanied with an energy and correlation level, providing the user with a clear understanding as to the validity of each reading. A graph of all acoustic echoes detected is provided, enabling a clear understanding of the acoustic environment of the member under test.

Upon completion of the survey a full report is automatically generated with readings and operator notes.

The core system components are shown below:



ISFMD Probe & Mount



ISFMD Cable Reel



ISFMD Topside Interface

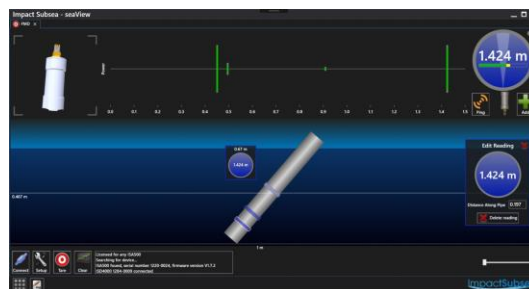

ISFMD Software

2.0 Specification

2.1 Probe Overview



2.2 Dimensions

2.2.1 Probe:

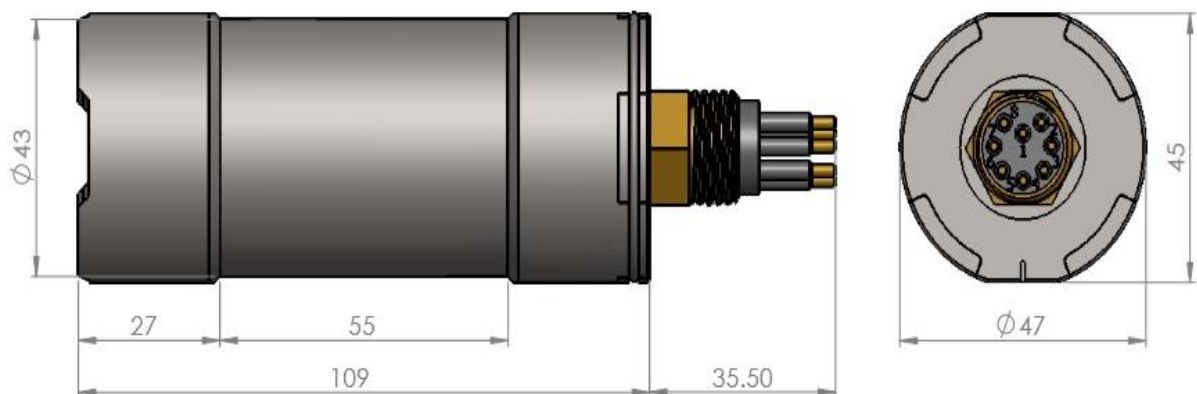

All dimensions are in mm.

2.2.2 Probe Mount:

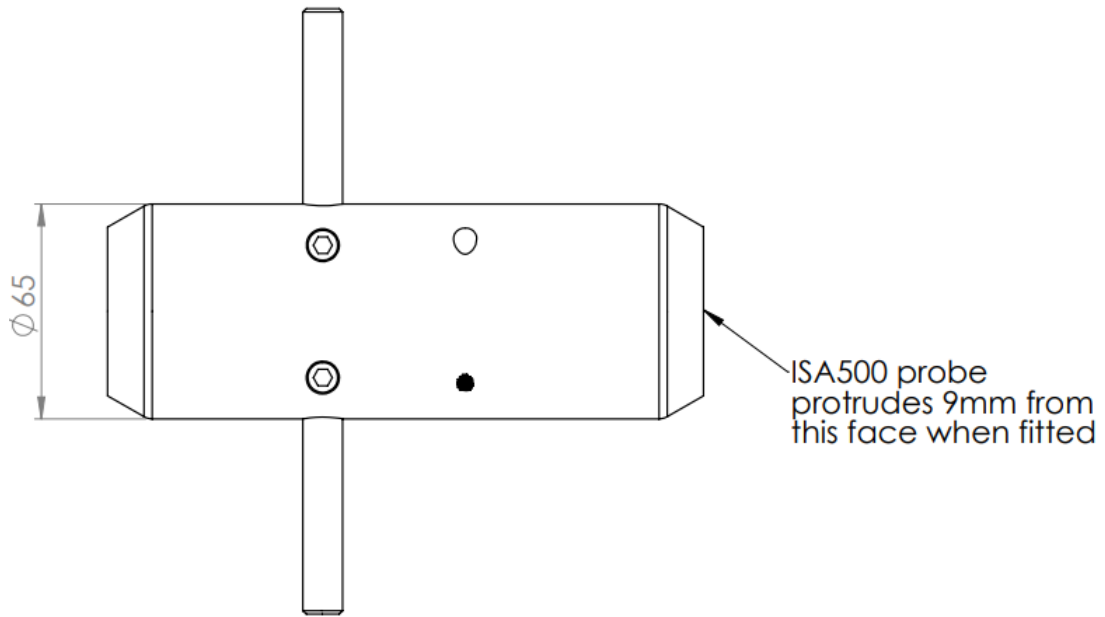

Top Down View

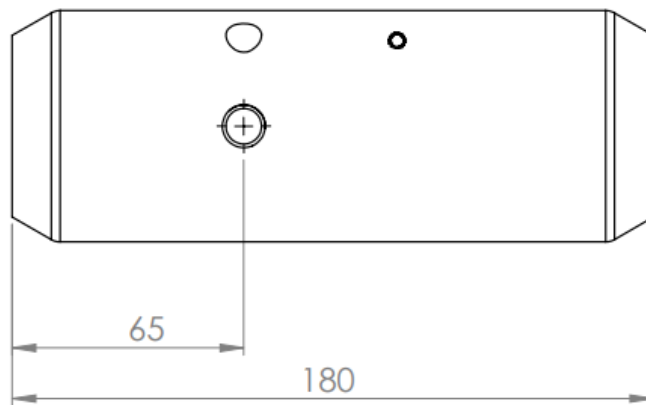

Side View

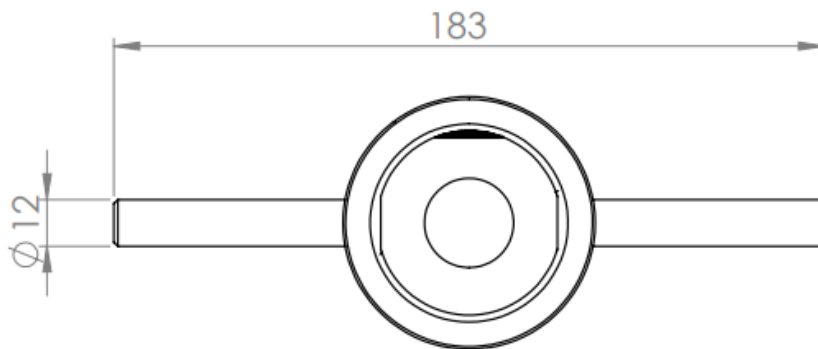

Front View

All dimensions are in mm.

2.3 Acoustic, Heading, Attitude & Temperature

Acoustic		Attitude	
Frequency	500kHz	Pitch Range	± 90°
		Roll Range	± 180°
Range	0.1 to 30m (Maximum range dependant on member type)	Accuracy	0.2°
Resolution	1mm	Resolution	0.1°
Beam Angle	6° conical in water	Temperature	
Signalling	Monotonic	Accuracy	0.5°
Pulse Length	Automatic	Resolution	0.1°
Heading			
Accuracy	± 1°		
Resolution	0.1°		

2.4 Communications, Power & Physical

Communications & Power		Physical	
Digital	RS232 & RS485	Weight (Air/Water)	0.5 / 0.325kg (Titanium)
Protocol	300 to 115200 baud	Depth Rating	4,000 meters (Titanium) 1,000 meters (Delrin®) (6,000 meters option)
Data Rate	Up to 10Hz	Temperature	Operating: -10 to 40° Storage: -20 to 50°
Input Voltage	9 to 36V DC	Connector	Subconn MCBH8M-SS fitted as standard
Power (Standby)	25mA @ 24V DC	* 100% Tx power	
Power (When Pinging)	51mA @ 24V DC *		

3.0 System Components

3.1 Probe

The ISA500 probe is the core sensor used in the ISFMD system. The ISA500 is a hydro-acoustic device, which transmits pulses of sound and detects corresponding returning echoes.

The probe operates at an acoustic frequency of 500kHz. The probe utilises a broadband composite transducer and electronics together with an advanced digital acoustic engine. The combination of these enable the probe to achieve a high level of sensitivity, making it an ideal FMD sensor probe.



ISA500 Probe

3.2 Probe Protective Holder

A robust acetal holder, complete with stainless steel (316) 'T-Bar', is provided for the ISA500 probe to protect the connector and cable.

The holder also allows the unit to be held securely by a diver or ROV manipulator during operation.



ISA500 Probe In Holder

3.3 Cable Reel

A 100 or 200 meter length of cable is supplied on a reel.

Subsea, the cable is terminated with a Subconn connector for quick connection to the ISA500 probe.

Topside the cable is terminated with a Souriau connector for quick connection to the topside interface box.



Cable Reel

3.4 Topside Interface Box

A topside interface box is provided to enable quick connection of all system components.

The supplied cable reel is terminated with a topside connector to connect to the 'ISA500' port.

A power supply is provided to connect to the 'PWR' port.

A USB lead is provided to connect to the 'USB' port of the Topside Interface Box and the desktop PC/Laptop.



Topside Interface Box

The topside interface box communicates with the ISA500 Probe using RS485 serial communications. The box then converts this communication protocol to USB for direct connection to a laptop or PC.

3.5 seaView Software

A powerful software package is provided to allow FMD survey readings to be made, recorded and populated into a report.

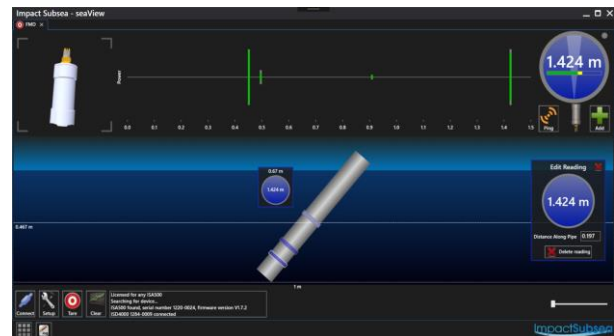

seaView Software

4.0 Hardware Setup

For use by a diver, please follow section 4.1 to setup the system. If installing to an ROV, please follow section 4.2

4.1 Diver Deployed System

Step 1: Unpack All Items from Transport Case

Step 2: Connect ISA500 Probe To Cable Reel:

- Ensure Cable Reel Probe connector is lightly greased with supplied grease
- Push Cable Reel Probe Connector through protective holder
- Push Cable Reel Probe Connector onto Probe connector
- Secure in place with red locking collar (hand tighten only)

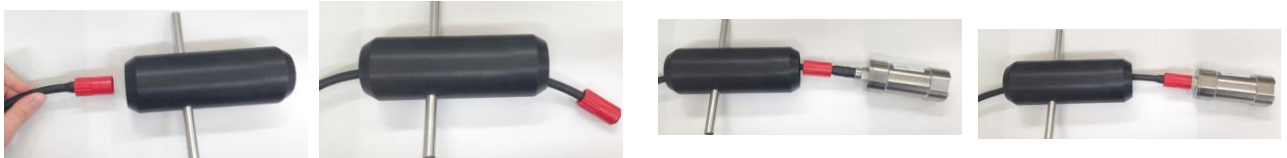

Step 3: Slide Probe Into Protective Holder:

- Align Probe flats with Holder flats
- Gently slide the Probe backwards into Holder
- Lock the Probe in place using 'Locking Bolt' (supplied with system)

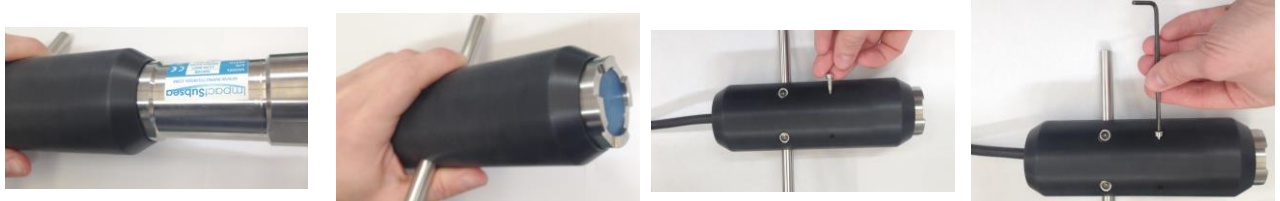

Step 4: Connector Topside Interface Box:

- Connect topside mating end of cable reel to 'ISA500' Port
- Connect USB Cable to 'USB' Port. Connect other end of USB cable to PC
- Connect Power Supply cable to 'PWR' port



The ISFMD system is now physically connected and ready for operation.

4.2 ROV Deployed System

For ROV installation, the ISA500 Probe should be mounted in its protective holder as per section 4.1 and held in the ROV manipulator.

The ISA500 is fitted with a SubConn MCBH8M-SS connector as standard. This will mate to a SubConn MCIL8F connector/cable assembly.

4.2.1 Connector Pin Out

The standard ISA500 connector pin out is provided below:

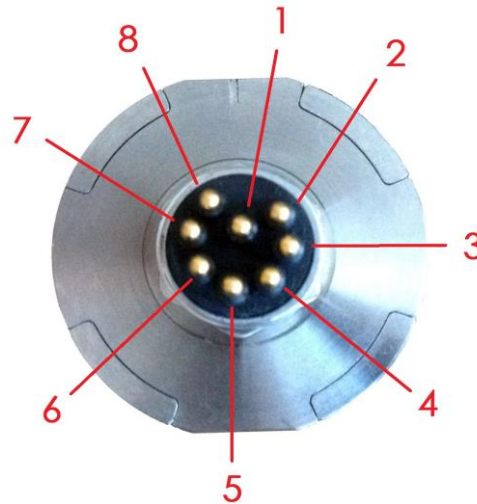

Male Connector on ISA500 Unit

Pin	Function	Mating Wire Colour
1	0VDC	Black
2	9-36VDC	White
3	Analogue Out	Red (Not used for FMD)
4	0V Analogue	Green (Not used for FMD)
5	0V Digital	Orange
6	Trigger	Blue (Not used for FMD)
7	RS232 TX & RS485 A+	White/Black
8	RS232 RX & RS485 B-	Red/Black

4.2.2 Power

The ISA500 is polarity protected and fused with a 400mA resettable poly fuse. Internal circuitry isolates the supply from the outside environment requiring the serial interface.

4.2.3 Serial Interface

The ISA500 serial communications protocol can be set to either RS232 or RS485. For use with the ISFMD Topside Interface box, the unit must be configured to RS485 communications.

The RS232 and RS485 interface is isolated from the supply and has in-line fused protection on the serial lines. A prolonged transient voltage on these lines will blow the surface mount fuses which will require replacement by Impact Subsea or an approved distributor.

4.2.4 RS232 Wiring

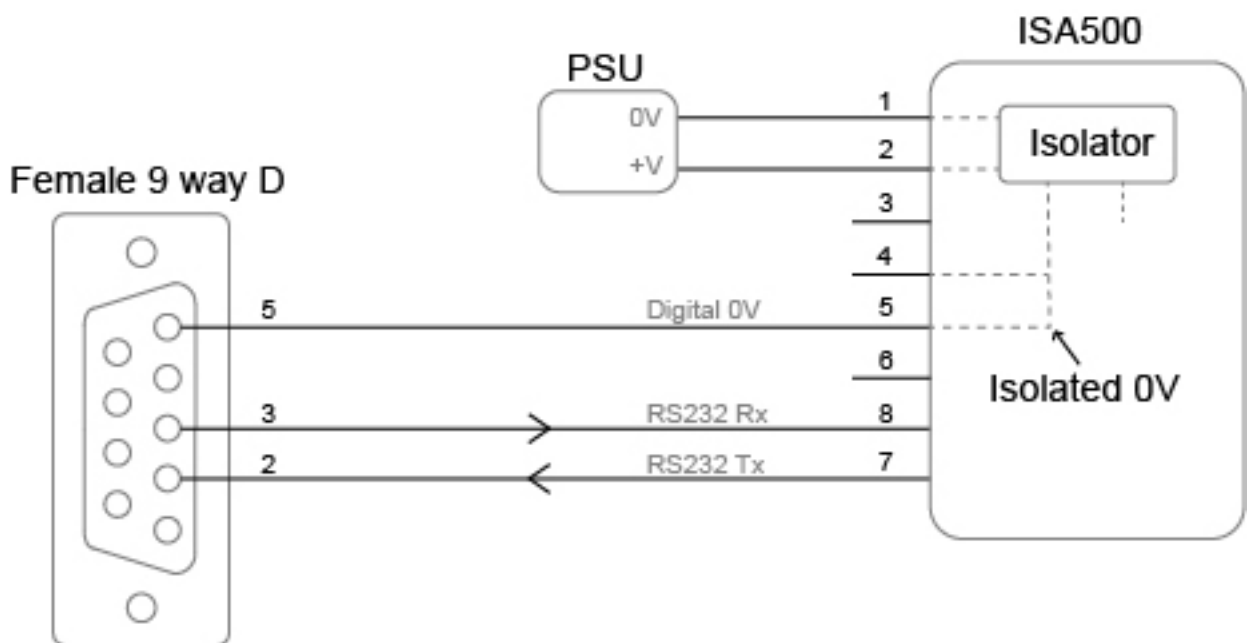

Note: RS232 will not function if the digital 0V pin is not use as the RS232 ground.

4.2.5 RS485 Wiring

The RS485 termination resistor is software selectable.

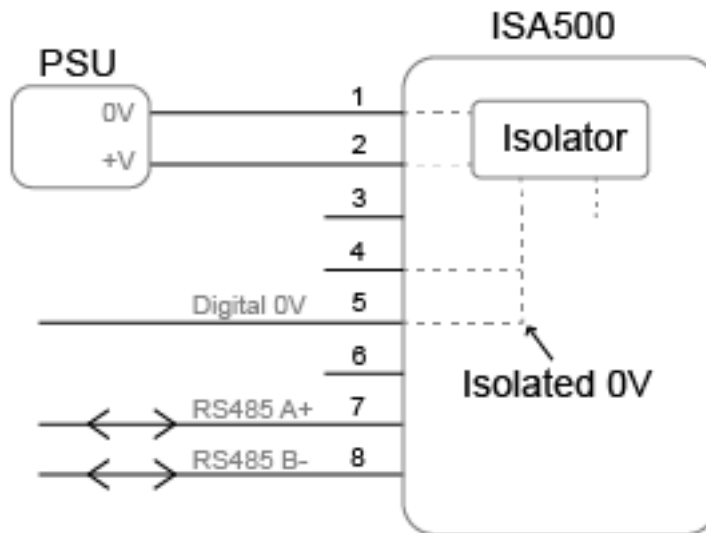

The digital 0V must be connected on an RS485 interfaces, otherwise the voltage potential between one of the A+ or B- lines to ground could reach a damaging level

4.2.6 Establishing Communications

The default serial settings for FMD are **RS485, 9600, N81**

If the communications require to be changed to RS232 or an alteration in baud rate is required, this can be conducted using the below method:

If the ISA500 is tilted from vertical to upside down 3 times within the first 10 seconds of power up then it will temporarily configure the serial interface to **RS232, 9600, N81** and output an ASCII message displaying the settings.

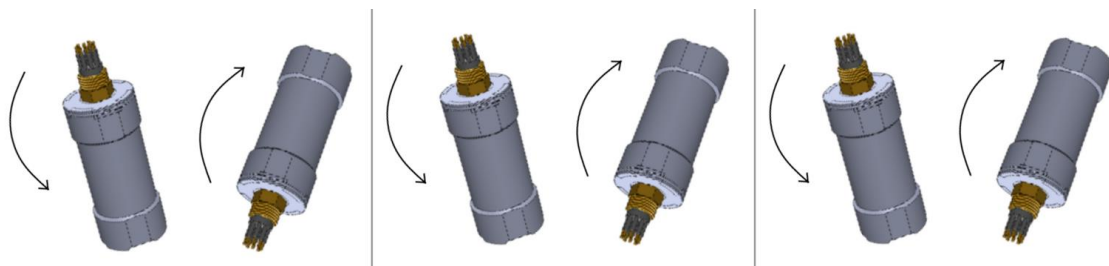

Note: When the device is power cycled the serial interface setting will revert back to the last configuration.

4.2.7 Connector Mating

When mating the cable to the SubConn connector, to maximise the life of the connector, it is important to observe the following:

- Always apply grease before mating. Molykote 44 Medium grease must be used.
- Disconnect by pulling straight, not at an angle.
- Do not pull on the cable and avoid sharp bends at cable entry.
- Do not over-tighten the bulkhead nut.

Do not expose the connector to extended periods of heat or direct sunlight. If a connector becomes very dry, it should be soaked in fresh water before use

5.0 Software Installation

The seaView software requires a desktop PC or laptop running Windows 7, 8 or 10 operating system.

For optimum performance, a wide screen monitor should be used. To install and run the software, please do the following:

- Plug the 'Impact Subsea' supplied USB stick into computer USB port
- Copy 'seaView' and 'FMD License' from the USB stick to the Windows desktop



- Run 'seaView'
- Click on the 'Start Here' icon

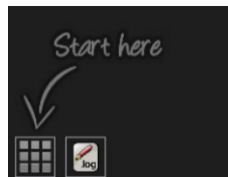

- Select 'FMD' and 'OK'

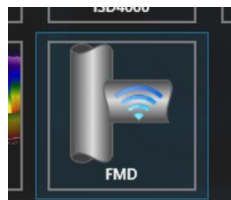

- Click 'Connect' in the lower left corner of the screen
- Select 'Comm Port' that the ISA500 Probe is connected to.
 - Hint - check Windows Device Manager if required
- Click 'Connect'

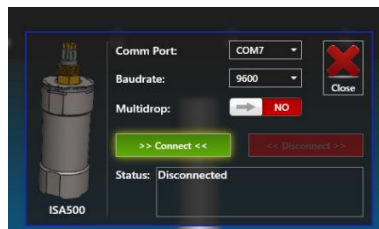

- Once Connected click 'Close'

A video of the above process can be viewed in the 'FMD' section of the Impact Subsea website.

6.0 Conducting An FMD Test

Having completed the hardware setup (Section 4.0) and software setup (Section 5.0) the ISFMD system is now ready for operation.

For certainty of operation, it is recommended that prior to testing members subsea, a known flooded member/non flooded member should be checked to ensure system is setup correctly and fully operational.

Using the seaView FMD application, conduct a FMD test as follows:

Step 1: Input parameters of member to be tested

- Click on 'Setup'
 - Input member Diameter (**Critical**)
 - Input Transmit Power (**Critical**)
 - Set Length of member (if known)
 - Set Member Angle (if known)
 - Set Depth of lowest point (if known)

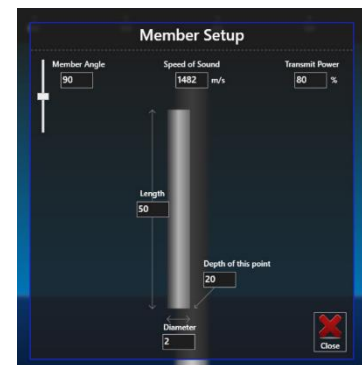

Clicking the 'Close' button will save the settings and automatically configure the acoustic settings of the ISA500 Probe to suit the member to be tested.

It is critical that a correct member diameter (in meters) is entered - the system will restrict the test window to the range entered - ignoring any returns beyond this range.

It is also critical that a sufficient power level has been chosen for the member under test. In general the power level should be set to as high as possible without causing spurious readings.

Step 2: Place the ISA500 blue circular transducer in direct contact with the member to be tested. The mating surface of the member should be clean and free from marine growth

Step 3: Click on 'Ping' in the seaView FMD Application

- If a return is detected the distance measured will be displayed in the pipe profile. This indicates that the member is flooded:
- If no return is detected, no value will be shown in the pipe profile. This indicates that the member is not flooded:

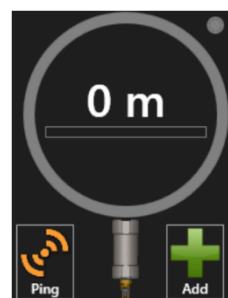

Example: Not Flooded

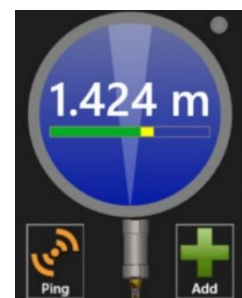

Example: Flooded

Step 4: Add reading to on-screen display of Member

- Click '**Add**' to record a reading on the Member and to include in the final report.
- The distance along the member/pipe that the reading was taken (in meters) can be entered at this point.

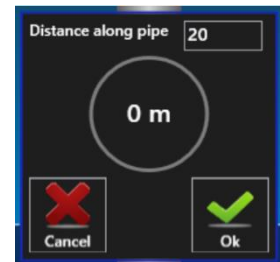

Step 5: Repeat the above process at all points on the member that you wish to check.

As readings are made and added, the member on screen will show each reading at its relative position. Clicking on the measurement on screen will allow that measurement to be deleted or its distance along the pipe edited:

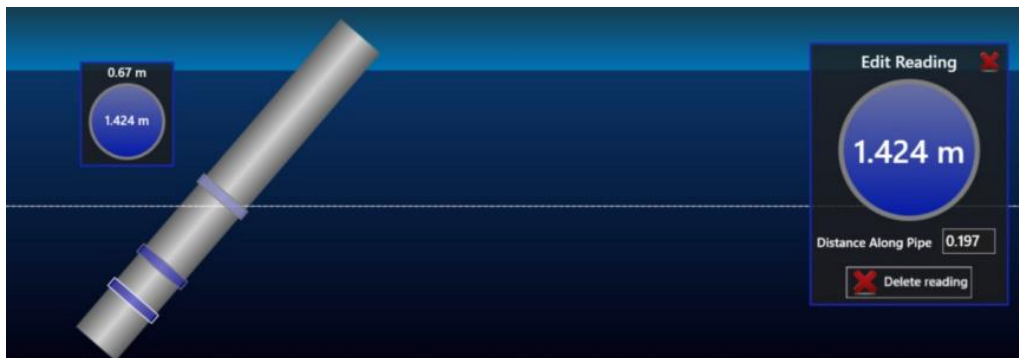

6.1 Understanding FMD Readings

Within the reading window, there is a bar of yellow and green for any measurement that detects the presence of water/liquid:



The yellow bar shows the total energy level received back at the ISA500 probe.

The green bar shows the proportion of that energy that is a valid echo.

The yellow energy bar ranges from 0 to 1 where 1 represents full saturation of the ISA500 Probe receiver. An energy level of 0.707 (square root of 2) is the theoretical perfect level as it represents the energy of a pure sine wave with an amplitude utilising the maximum dynamic range of the ISA500.

The green bar ranges from 0 to 1 which represents a quality factor of the returned echo. A value of 1 would represent a return echo of perfection with negligible noise and distortion.

The correlation value can be used alone as a trust factor where low values would mean there a good possibility it's a false reading. A more detailed picture can be built by combining this information with the energy level as shown in the table:

	Low energy levels	High energy levels
Low correlation	Weak signal probably false reading	High noise level most likely a false reading
High correlation	Weak signal but likely a good reading	Ideal conditions very trust worthy readings

These values can also give some insight for adjusting the transmit power. If the energy level is low then consider increasing the amplitude of the transmit pulse (under '**Setup**' in the seaView FMD application).

Please note, it is the responsibility of the user of the ISFMD system to satisfy him/herself as to the validity of readings.

In conjunction with the reading window, which shows the reading the ISFMD system has used for range measurement, all other detected echoes can be viewed in the display to the left:

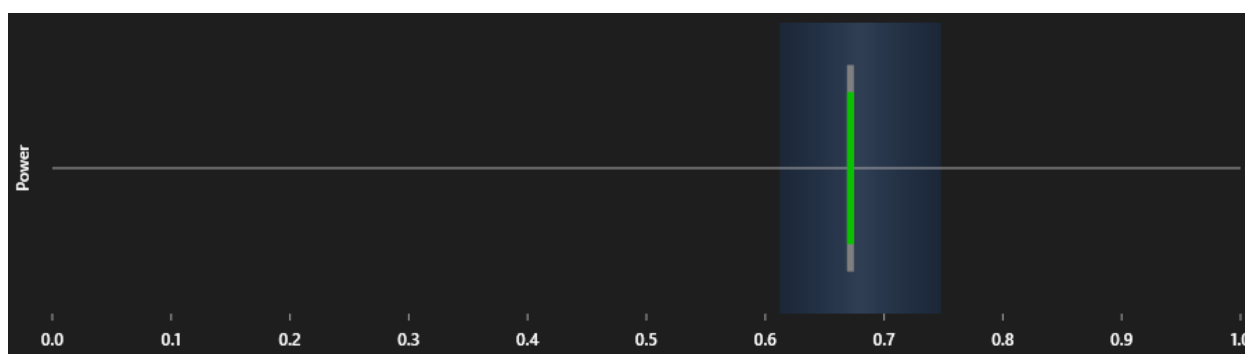

Echo Detected at Member Diameter

On the above display, the area where a return is expected to be received if a member is flooded is highlighted in **blue**. If a return is received in this area the member is considered flooded:

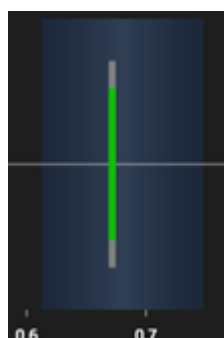

The blue window extends +/- 10% of the member diameter to account for variations in speed of sound through the member wall and internal medium*.

As with any acoustic based FMD system, when an acoustic pulse is transmitted into a flooded member, it is usual to detect an acoustic return from the back wall.

There may be other echoes however, from any item suspended in the water or from multi-path effects.

The above window allows the operator to see each acoustic echo the ISA500 probe has detected. The x-axis represents range (in meters) with the y-axis representing power level of each echo.

This window is provided to create a clear view of the acoustic environment within the flooded member.

**Note – the blue window is only in seaView versions 1.9.1 and above.*

7.0 Servicing

The ISFMD system is a highly robust measurement device. The system has been designed to require minimal maintenance, and as such there are no user serviceable components within the system.

The ISA500 probe should be rinsed in fresh water after each use to remove salt deposits. If required a light detergent (such as that used to clean household dishes) can be used.

DO NOT USE SOLVENTS TO CLEAN THE UNIT

Following rinsing the unit should be dried with a cloth.

The connector should be cleaned, and a light coating of Molykote 44 Medium grease should be applied.

The unit should be stored in its original case, in a cool, dry place.

It is recommended that the unit be returned to Impact Subsea Ltd, on an annual basis to have a health check and service conducted.

8.0 Theory of Operation

8.1 Flooded Member Detection - Basic Principles

This section examines how Flooded Member Detection is achieved by the system.

For the purpose of detecting Flooded Members, the ISA500 is a hydro-acoustic device, which utilises sound pressure waves in order to determine the presence of water or liquid in a member.

Acoustics (also known as hydro-acoustics or sound pressure waves) are used by the ISA500 due to their high efficiency in travelling through water or liquid. Through water acoustics can travel far greater distances than signals in the light or radio frequency spectrum. Thus, are the ideal method to use for measuring distance underwater.



The ISA500 operates by emitting an acoustic pulse into the member to be tested. This pulse travels through the water, the wall of the member and into the inside.

If the member is full of water/liquid (flooded) the sound will continue through the member to the corresponding side.

At which point part of the pulse is reflected back to the ISA500.

This reflected portion is detected by the ISA500 and the time taken for this acoustic pulse to travel from the ISA500, bounce off the corresponding member wall and return is recorded.

The distance the acoustic pulse has travelled can then be calculated by the simple equation:

$$\text{Distance} = \text{Speed} \times \text{Time}$$

In water, the speed of sound is typically around 1,500 meters per second. This is influenced by various factors (temperature, salinity & pressure). However, for the purpose of this explanation, we will assume a speed of sound of 1,500m/s.

For example, if an acoustic pulse takes 0.001 seconds to return to the ISA500 after being sent, we can calculate its round-trip travel distance as:

$$\begin{aligned} \text{Distance} &= \text{Speed} \times \text{Time} \\ &= 1,500 \times 0.001 \\ &= 1.5\text{m} \end{aligned}$$

Therefore, the total distance the sound has travelled is 1.5m (journey to the member back wall + journey back from the member back wall).

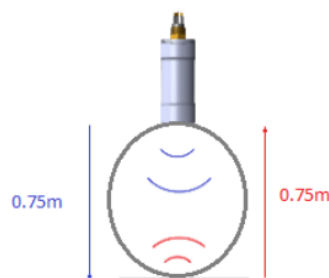

To calculate the distance measured, we simply half this value.

i.e. the range to the other side of the member is 0.75m.

9.0 Common Questions & Answers

Q. I have connected the ISA500 to the Topside Interface Box but cannot establish communications with the unit.

A. In order for the ISA500 Probe to operate with the Topside Interface Box, the probe must be set to RS485 communications.

If the unit is set to RS232, the communications can be changed back to RS485 using the ISA500 Application.

Q. In the seaView software there are many applications (ISA500, ISD4000, FMD etc) - which do I use for Flooded Member Detection?

A. Only the 'FMD' application is required for Flooded Member Detection work. seaView has the ability to support all Impact Subsea sensors and thus has an application to suit each.

The FMD application will configure the ISA500 acoustic settings (pulse length, min & max range etc) to suit each member under test. There is no requirement to manually adjust the acoustic settings of the ISA500.

Do not use the ISA500 application while the FMD application is open. The ISA500 application is intended to use the ISA500 Probe as an Altimeter.

Q. When conducting the FMD test, does the ISA500 probe have to be touching the member under test?

A. In theory the ISA500 probe can be slightly away from the member under test, however it is recommended that the ISA500 probe is in direct physical contact with the member under test.

Q. When conducting the FMD test, do I need to remove marine growth from the member prior to test?

A. All marine growth must be removed prior to the ISA500 probe being coupled to the member under test. The ISFMD system operates through the use of acoustics and thus requires a good acoustic coupling to be made with the member under test.

Q. I have tested the ISFMD setup in the workshop in advance of deploying subsea. In some tests, I get a small reading (0.1m to 0.30m) for non-flooded member. What is causing this?

A. We would recommend checking the transmit power level (FMD -> Member Setup -> Transmit Power). In some environments, an acoustic return may be produced by the member under test due to its own acoustic properties (even when not flooded). Reducing the transmit level will reduce the energy being transmitted into the member and remove the small reading.

Please note, the transmit level should only be reduced to a level to remove noise, not to a level which would prevent detection of the flooded member.

It is recommended that the transmit pulse level is reduced in 5% increments until the noise is no longer apparent.

The system should then be tested against a known flooded/unflooded member in question to verify settings.

Q. The ISFMD system appears to be for use only underwater. Can I use this system in air?

A. The ISFMD system has been designed to work underwater, using the water as a coupling medium to the member to be tested.

The system can be used in air, but will require a coupling jell to ensure a good acoustic contact between the ISA500 probe and the surface member under test.

10.0 Warranty

The ISFMD System is supplied with a Limited Warranty. This warranty applies only to the ISFMD System and only if the ISFMD system is purchased from Impact Subsea Ltd or recognised distributor.

What does the limited warranty cover?

This Limited Warranty covers any defects in material or workmanship under normal use during the Warranty Period.

During the Warranty Period, Impact Subsea Ltd will repair or replace, at no charge, products or part of a product that prove defective because of improper material or workmanship under normal use and maintenance.

What will we do to correct the problems?

Impact Subsea Ltd will either replace or repair the Product at no charge, using new or refurbished replacement parts. Replacement or repair is at the discretion of Impact Subsea Ltd.

How long does the coverage last?

The Warranty Period for the ISFMD System, purchased from Impact Subsea Ltd, is 1 year from the date of dispatch from Impact Subsea Ltd.

A replacement ISFMD System, or part assumes the remaining warranty of the original ISFMD System or 60 days from the replacement or repair, whichever is longer.

What does this limited warranty not cover?

This limited warranty does not cover any problem that is caused by conditions, malfunctions or damage not resulting from the defects in material or workmanship.

What do you have to do?

To obtain a warranty repair of your ISA500 unit, you must first contact Impact Subsea Support to determine the problem and the most appropriate solution for you.

11.0 Technical Support

Should you require technical support for your ISFMD System, our Support team can be contacted as follows:

T. +44 (0) 1224 460 850

E. support@impactsubsea.co.uk

W. www.impactsubsea.com

An out of hours emergency number is available via the Impact Subsea website.

Utilising the above email address will ensure that all support engineers are copied into your support request, and will ensure a prompt response.

When contacting our Support team, please provide the following details of the ISFMD system:

- Serial Number (ISA500, Topbox, Reel etc)
- Firmware version of ISA500
- seaView version (if applicable)
- Fault Description
- Remedial action undertaken thus far

For further reading on the ISFMD system (including explanatory videos, datasheets, quick start guides etc) please consult the FMD section of the Impact Subsea website.

Every effort is made to ensure that information within this document is up to date. However, information within this document is subject to change without notice, in-line with our commitment to continuous product development and improvement.