

ISD4000

Depth & Temperature Sensor With Optional AHRS



Installation & Operation Manual

Revision Number:	1.8
Date	16 th April 2020

1.0	Introduction	2
2.0	Specification	3
2.1	ISD4000 Overview	3
2.2	ISD4000 Dimensions	3
2.3	Depth, Temperature & AHRS	4
2.4	Communications, Power & Physical	4
3.0	Overview	5
4.0	Installation	6
4.1	Location	6
4.1.1	Pressure (For Depth Accuracy)	6
4.1.2	Magnetic Disturbers (For Heading Accuracy)	6
4.1.3	Alignment with Vehicle (For Pitch/Roll Accuracy)	6
4.1.4	Heat Sources (For Temperature Accuracy)	7
4.2	Mounting	8
4.3	Electrical	9
4.3.1	Connector Pin Out	9
4.3.2	Power	10
4.3.3	Serial Interface	10
4.3.4	RS232 Wiring	10
4.3.5	RS485 Wiring	11
4.3.6	Establishing Communications	11
4.3.7	Connector Mating	12
4.3.8	Connector Cleaning	12
5.0	Operation	13
5.1	Use With The Impact Subsea Software	13
5.2	Integration With Systems	14
5.3	Calibration	14
5.4	Magnetic Calibration	15
6.0	ASCII Output Strings	20
6.1	Depth	20
6.2	AHRS	21
7.0	Servicing	24
8.0	Warranty	25
9.0	Technical Support	26

Every effort is made to ensure that information within this document is up to date. However, information within this document is subject to change without notice, in-line with our commitment to continuous product development and improvement.

1.0 Introduction

The ISD4000 sensor provides depth and temperature measurement with exceptional accuracy and resolution. Optionally, the ISD4000 can also measure Heading, Pitch & Roll.

Suitable for a large range of underwater applications, the ISD4000 can be used with ROVs, AUVs, Hydro-graphic Survey, Construction, Positioning and any other task where accurate depth and temperature is required underwater.

The ISD4000 utilises the latest in temperature compensated piezo-resistive depth sensing technology, to provide an exceptional 0.01% full scale depth measurement accuracy. A highly accurate RTD sensor is used to provide temperature to 0.01°C accuracy.

Where fitted, the Heading, Pitch and Roll readings are provided from integrated MEMs based Magnetometers, Accelerometers and Gyroscopes. The MEMs based devices are fused together to provide highly accurate and stable Heading, Pitch and Roll measurements.

Housed in a compact and lightweight titanium or acetal housing ensures that the ISD4000 is not only at the forefront of sensor technology; but is built to withstand the most extreme underwater environments.



ISD4000 Depth & Temperature Sensor

2.0 Specification

2.1 ISD4000 Overview

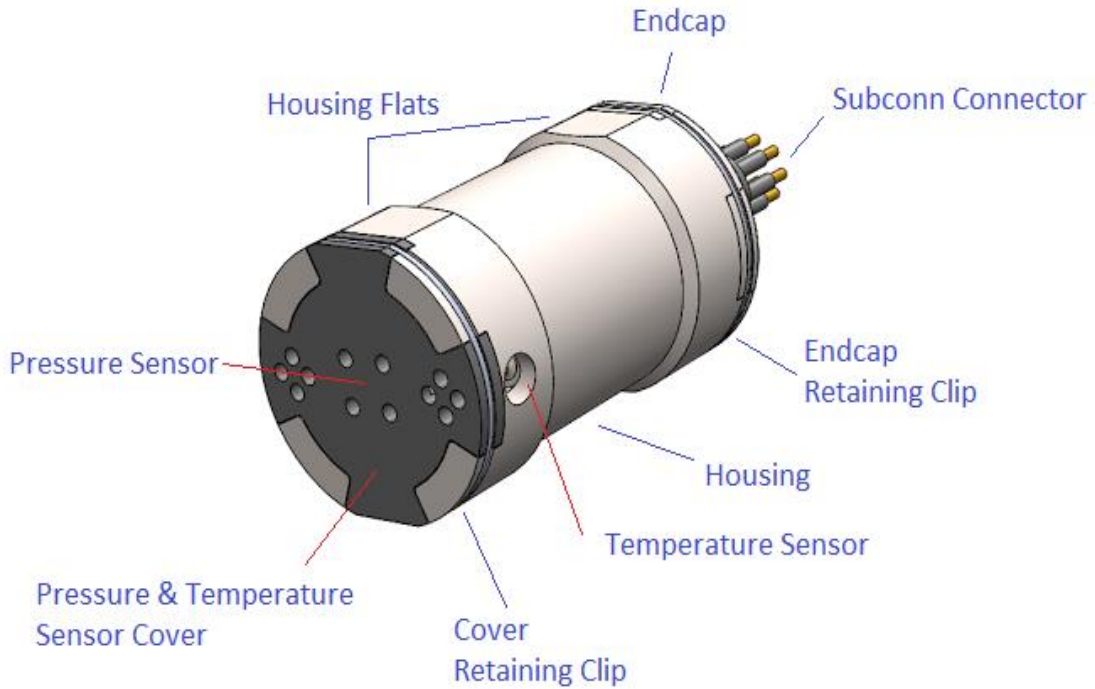

2.2 ISD4000 Dimensions

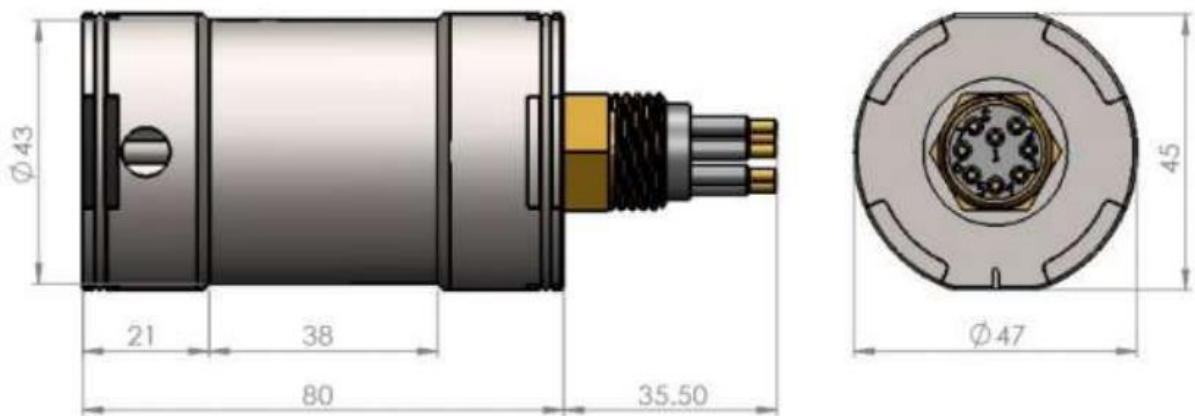

All dimensions are in mm.

2.3 Depth, Temperature & AHRS

Depth		Pitch & Roll*	
Accuracy	± 0.01% Full Scale	Pitch	± 90°
		Roll	± 180°
Resolution	0.001% Full Scale	Accuracy	0.2° RMS
Range	10, 30, 50, 100, 300, 400 or 600 Bar	Resolution	0.1°
Type	Temperature Compensated Piezo-Resistive		
Temperature			
Accuracy	0.01°C		
Resolution	0.001°C		
Heading*			
Accuracy	± 0.5°		
Resolution	0.1°		

* Optional

2.4 Communications, Power & Physical

Communications & Power		Physical	
Digital	RS232 & RS485	Weight (Air/Water)	Titanium: 0.42 / 0.28kg Acetal: 0.20 / 0.10kg
Protocol	300 to 115200 baud	Depth Rating	Titanium: 6,000 meters Acetal: 500 meters
Data	Continuous or on demand	Temperature	Calibrated: -5 to 25° Operating: -10 to 60° Storage: -20 to 70°
Data Rate	Up to 100Hz	Connector	Subconn MCBH8M-SS fitted as standard
Input Voltage	7 to 32V DC		
Power	< 40mA @ 24V DC		

3.0 Overview

The ISD4000 is a pressure measurement device – making use of increasing pressure in water to determine depth. It is important to note that the device is designed to provide depth & temperature measurements in water, and will not provide accurate readings when operated in air.

The Heading, Pitch and Roll readings are provided by a Micro-Electro-Mechanical system (MEMS) based technology. MEMs based Gyros, Accelerometers and Magnetometers are integrated within the unit.

The temperature reading is provided by a dedicated RTD sensor, located in a probe next to the pressure sensor.

The ISD4000 can be configured using the supplied Impact Subsea software. The software allows all settings to be configured (output strings, communications protocol, baud rate, taring etc).

In addition to allowing the ISD4000 to be configured, the Impact Subsea software also allows all outputs to be viewed in real time and logged.

4.0 Installation

4.1 Location

When evaluating the installation location of the ISD4000, there are several factors to consider to achieve optimum operation from each part of the unit:

- **Pressure** (Depth Measurement)
- **Magnetic Disturbers** (Heading)
- **Alignment with Vehicle** (Pitch/Roll)
- **Heat Sources** (Temperature Measurement)

4.1.1 Pressure (For Depth Accuracy)

The ISD4000 pressure port must not be blocked or obstructed by any item. Take care when mounting the unit not to block any of the holes on the pressure port of the ISD4000.

The unit should be mounted to allow good water flow to the pressure sensor.

Ideally the ISD4000 should be mounted with the pressure sensor end pointing downwards. This will help to minimise the build-up of sediment on the pressure sensor.

4.1.2 Magnetic Disturbers (For Heading Accuracy)

Where the heading output is to be used, the ISD4000 should be mounted as far as possible from sources of magnetic interference.

Electrical items which can cause magnetic interference include motors, transformers and valve packs. Ferrous metals, or any other magnetically active materials will also have influence on the heading reading. Thus, where possible, the unit should be installed as far as possible from magnetically active materials.

4.1.3 Alignment with Vehicle (For Pitch/Roll Accuracy)

When mounting **vertically**, the ISD4000 should be mounted with the Pressure Sensor facing downwards (to the seabed) and the indentation in the connector end cap pointing forwards, in the direction of forward vehicle travel:

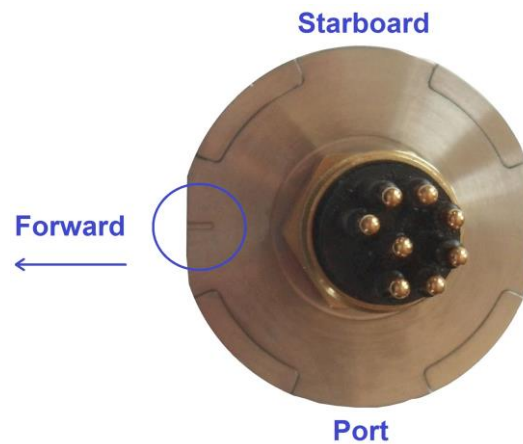

When mounting **horizontally** the ISD4000 should be installed with the indentation in the connector end cap pointing upwards:

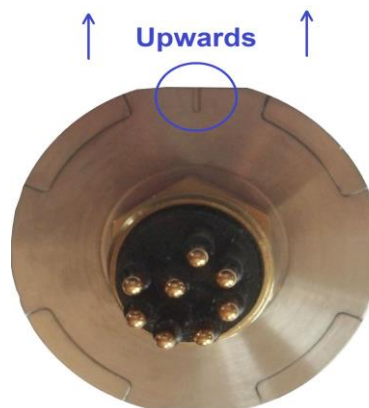

4.1.4 Heat Sources (For Temperature Accuracy)

In order for the ISD4000 to read the ambient temperature of the water, it should not be installed in close proximity of any heat sources (such as Hydraulic Power Packs).

4.2 Mounting

The ISD4000 should be mounted using clamps around the mid-section of the body. The unit has a 38mm recess in the main body to enable a clamp to be tightened securely around the unit:

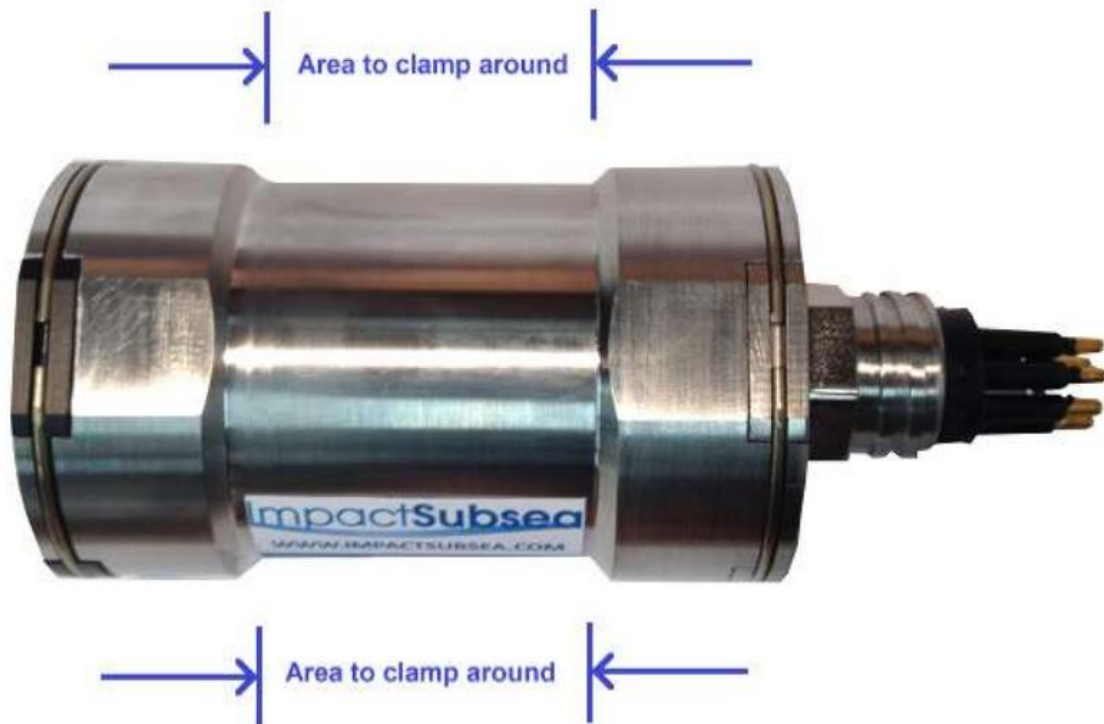

Ideally a non-metallic clamp should be used, however in the event that this is not possible, effort should be made to electrically isolate the clamp from the ISD4000 housing. This can be achieved by using rubber or plastic strips around the body of the ISD4000.

The ISD4000 has two flats, on either side of the body – these are to enable the unit to sit tightly against another flat surface if available. These flats also help prevent the unit moving when on the workbench for testing.

4.3 Electrical

The ISD4000 is fitted with a SubConn MCBH8M-SS connector as standard. This will mate to a SubConn MCIL8F connector/cable assembly.

4.3.1 Connector Pin Out

The standard connector pin out is provided below:

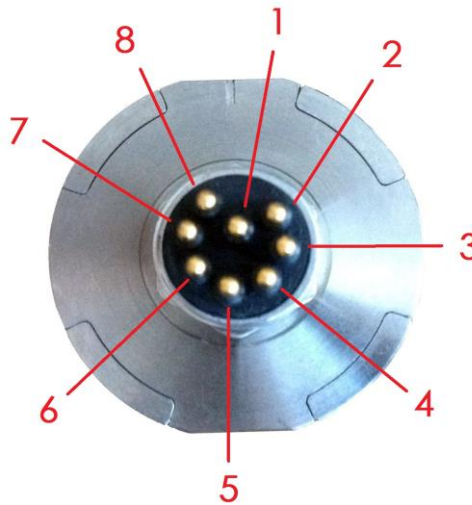

Male Connector on ISD4000 Unit

Pin	Function	Mating Wire Colour
1	0VDC	Black
2	7-32VDC	White
3	Not Used	Red
4	Not Used	Green
5	0V Digital	Orange
6	Not Used	Blue
7	RS232 TX & RS485 A+	White/Black
8	RS232 RX & RS485 B-	Red/Black

4.3.2 Power

The ISD4000 is polarity protected and fused with a 400mA resettable poly fuse. Internal circuitry isolates the supply from the outside environment requiring the serial interface to use the digital 0v reference pin.

4.3.3 Serial Interface

The RS232 and RS485 interface is isolated from the supply and has in-line fused protection on the serial lines. A prolonged transient voltage on these lines will blow the surface mount fuses which will require replacement by Impact Subsea or an approved distributor.

4.3.4 RS232 Wiring

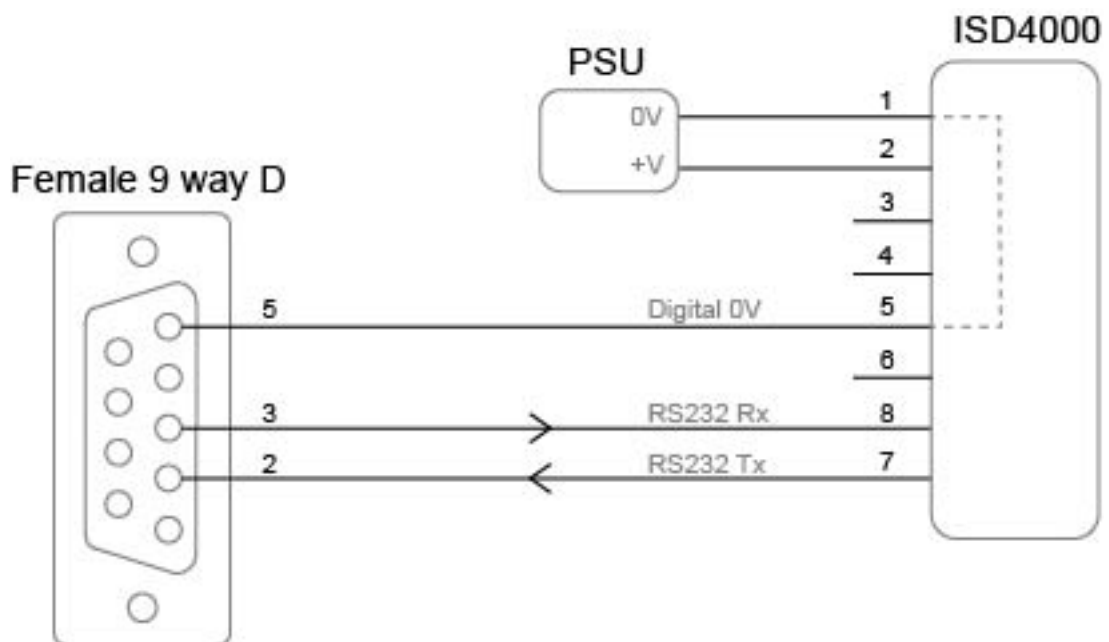

4.3.5 RS485 Wiring

The RS485 termination resistor is software selectable.

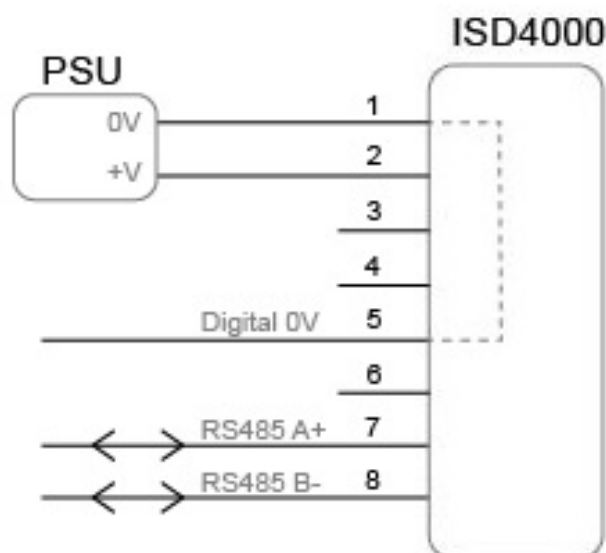

The digital 0V must be connected on an RS485 interface, otherwise the voltage potential between one of the A+ or B- lines to ground could reach a damaging level

4.3.6 Establishing Communications

The default serial settings are **RS232, 9600, N81**

If the ISD4000 is tilted from vertical to upside down 3 times within the first 10 seconds of power up then it will temporarily configure the serial interface to the default and output an ASCII message with the settings.

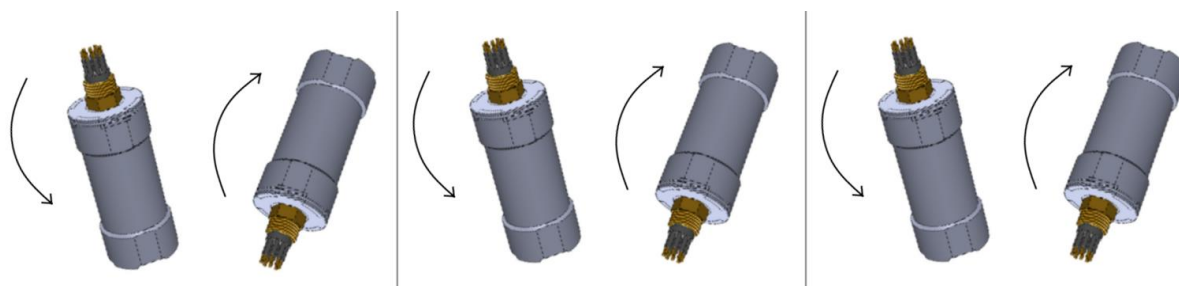

Note: When the device is powered cycled the serial interface setting will revert back to the last configuration.

4.3.7 Connector Mating

When mating the cable to the SubConn connector, to maximise the life of the connector, it is important to observe the following:

- Always apply grease before mating. Molykote 44 Medium grease must be used.
- Disconnect by pulling straight, not at an angle.
- Do not pull on the cable and avoid sharp bends at cable entry.
- Do not over-tighten the bulkhead nut.

Do not expose the connector to extended periods of heat or direct sunlight. If a connector becomes very dry, it should be soaked in fresh water before use

4.3.8 Connector Cleaning

General cleaning and removal of any accumulated sand or mud on a connector should be performed using spray based cleaner (for example Isopropyl Alcohol).

New grease must be applied again prior to mating.

5.0 Operation

5.1 Use With The Impact Subsea Software

The ISD4000 is supplied with the highly intuitive Impact Subsea software on USB. The latest version of this software can also be downloaded from www.impactsubsea.com.

The Impact Subsea software is designed to operate all of the Impact Subsea sensors. Single sensors can be operated, or multiple sensors together.

The software is designed for use with a PC running the Windows 7, 8 or 10 operating system and require Microsoft's .net framework 4.5.2 or above

The software uses an advance framed binary protocol to communicate to the ISD4000 and can do so over RS232 or RS485 at any standard baud rates above 4800. The parity must be none, stop bits 1 and data bits 8. If the ISD4000 communication settings differ from this then perform the comms reset as described in the establishing comms section of this manual.

All settings and offsets are saved to the ISD4000 device flash memory.

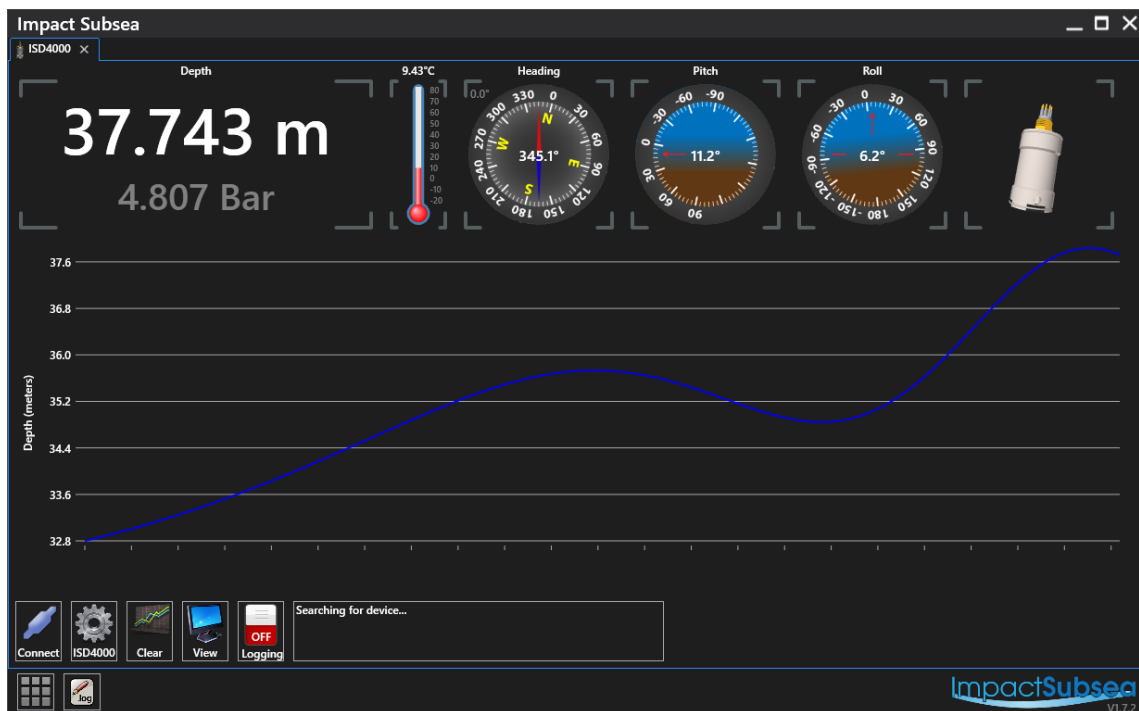

Impact Subsea Software

5.2 Integration With Systems

Conceptually there are two modes of operation, Interrogated and Autonomous.

Integration mode requires a master to request the ISD4000 to make a measurement and report this back.

The ISD4000 can be interrogated by the user defined interrogation string. Upon interrogation the ISD4000 will make a measurement and report back the result over the serial interface.

Autonomous mode will make a measurement and output the results at a specified time interval.

The ISD4000 can be configured to operate in one or both of these modes at the same time.

ISD4000's with the AHRS option make use of the same Interrogated and autonomous mechanisms to output heading pitch and roll data over the serial interface.

5.3 Calibration

The ISD4000 unit is supplied fully calibrated and should not require further calibration prior to use. The calibration interval is one year.

The unit can be calibrated using a standard deadweight tester combined with the ISD4000 calibration block. This is available from Impact Subsea.

Using the Impact Subsea Software, a calibration of both temperature and pressure can be performed on the ISD4000. The software provides a step by step guide to talk the user through the calibration procedure.



ISD4000 Calibration Block

5.4 Magnetic Calibration

Following final physical installation on the vehicle (or other structure) it is critical that a magnetic calibration is conducted.

The magnetic calibration takes into account all local hard and soft iron artefacts of the vehicle (or other structure the ISD4000 is mounted to). This enables the correction of any heading offsets that permanent magnetic interferers may cause.

If the magnetic calibration is not conducted, the heading will not be correct and will suffer from non-linear movement when rotated. For example, when operating with inertial mode disabled, a 90° physical rotation may only be recognised as an 80° rotation.

To conduct a good magnetic calibration, please complete the following procedure. There is also a video demonstration of this procedure available on the ISD4000 page of the Impact Subsea website.

5.4.1 Magnetic Calibration Procedure

Step 1: Ensure that the ISD4000 has been physically installed in a location as free from magnetic interference as possible (away from valve packs, thrusters etc).

Step 2: Check that the ISD4000 is mounted securely to the structure ensuring the unit is not able to move independently from the structure.

Step 3: If conducting the magnetic calibration in a workshop, ideally hang the ROV from a crane away from magnetic sources. If conducting the calibration at sea, deploy the ROV and move into open water, away from any structures with a magnetic property (vessel, pipeline etc). **Do not conduct the calibration with the ROV on the vessel.**

Step 4: Run the seaView software, select the ISD4000 application and connect to the ISD4000 unit:



Step 5: Once connected to the ISD4000, go into the ISD4000 settings (Gear Cog graphic)

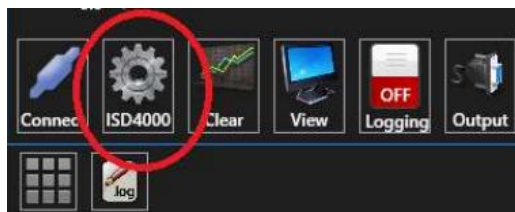

Step 6: Navigate to the AHRS Setup page and click on the 'Calibrate' button to open the calibration window:



Step 7: On the 'Mode' button, click this to change it to 'Calibrate'

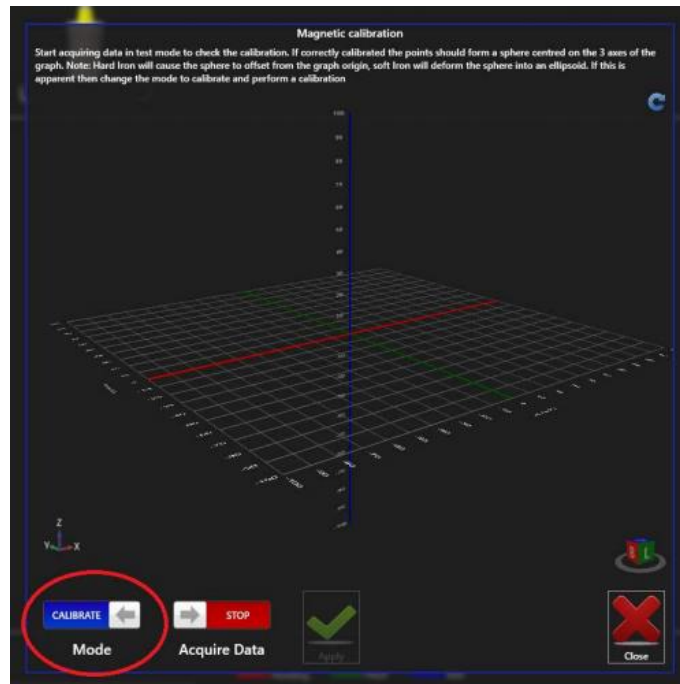

Step 8: On the 'Acquire Data' button change to 'Start'. The calibration process has now begun.



Step 9: Rotate the ROV through 360 degrees.

Step 10: Keep rotating the ROV through 360 degrees and pitch/roll the ROV as much as

is possible.

On screen you will see the sides of a ball forming from a number of dots. Click on the ball to rotate and see if there are any gaps in data. Physically move the ROV to fill this data.

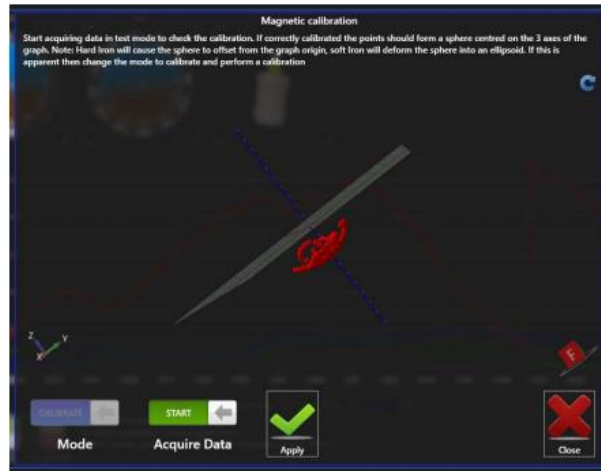

Continue this process for five to ten minutes, until a good amount of data points are visible on screen. The ideal calibration will result in a complete 3D ball on screen – this may not be achievable with large ROVs, but effort should be made to get as close to this as possible:

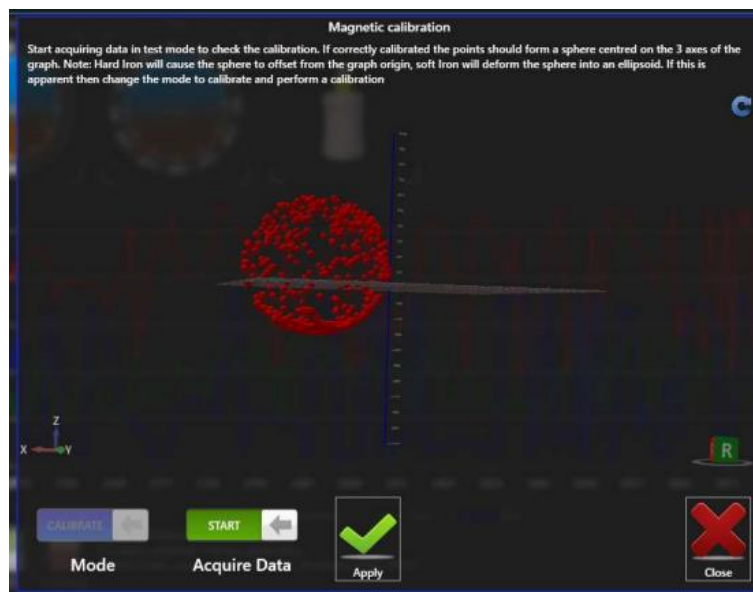

Step 11: Once you have completed the calibration click 'Apply' to save the calibration to the ISD4000 unit.



Step 12: Power Cycle the ISD4000 unit.

The ISD4000 will now point to magnetic north and provide good operation. If this is not the case, the magnetic calibration has not been completed to a sufficiently high standard and will require to be conducted again.

If a good calibration cannot be performed, due to lack of movement or excessive magnetic interference, ensure that the unit is set to operate in inertial mode. Power the unit and allow ten seconds for the heading to stabilise.

Once the heading has stabilised, a Heading Offset can be applied via the AHRS Setup page. This can be used to correct the heading of the unit to a known true value.

6.0 ASCII Output Strings

6.1 Depth

ID1: Impact Subsea Depth, Pressure and Temperature.

String format:

`$ISDPT,ddd.ddd,M,ppp.pppp,B,tt.tt,C*xx<CR><LF>`

ddd.ddd = depth in meters

ppp.pppp = absolute pressure in Bar

tt.tt = temperature in Celsius

xx = NMEA standard checksum

ID2: Valeport Depth

String format:

`$PIPS,ddd.dd,M*xx<CR><LF>`

ddd.dd = depth in meters

xx = NMEA standard checksum

ID3: Digiquartz Pressure

String format:

`*xxxxxx.xx<CR><LF>`

xxxxxx.xx = pressure in psi

ID4: PS-30 Depth and Temperature

String format:

`SdddEsxxTttt<CR><LF>`

ddd = pressure in bar * 100

s = sign + or -

xx = always set to -2

ttt = temperature in degrees celsius * 10

6.2 AHRS

ID1: Impact Subsea Heading, Pitch, Roll

String format:

$\$ISHPR,hhh.h,spp.p,srrr.r*xx<CR><LF>$

s = sign + or -

$hhh.h$ = heading in degrees (0 to 359.9)

$spp.p$ = pitch in degrees (90.0 to -90.0)

$srrr.r$ = roll in degrees (180.0 to -180.0)

xx = NMEA standard checksum

ID2: Impact Subsea Quaternion

Quaternions represent the orientation of a 3D body in a 4 dimensional world. This avoids the associated gimbal lock / singular problems with conventional heading, pitch, roll.

String format:

$\$ISQUA,w,x,y,z*xx<CR><LF>$

w = floating point number Q0

x = floating point number Q1

y = floating point number Q2

z = floating point number Q3

xx = NMEA standard checksum

ID3: TCM2 Compass, Pitch, Roll

String format:

$\$Chhh.h,Ppp.p,Rrr.r*xx<CR><LF>$

$hhh.h$ = heading in degrees (0 to 359.9)

$ppp.p$ = pitch in degrees (90.0 to -90.0)

$rrr.r$ = roll in degrees (90.0 to -90.0)

xx = NMEA standard checksum

ID4: Impact Subsea Accelerometer, Gyro, Magnetometer

String format:

$\$ISAGM,a.aaa,a.aaa,a.aaa,g.ggg,g.ggg,g.ggg,m.mmm,m.mmm,m.mmm*xx<CR><LF>$

a.aaa = Accelerometer reading: X then Y then Z

g.ggg = Gyroscope reading: X then Y then Z

m.mmm = magnetometer reading: X then Y then Z

xx = NMEA standard checksum

All values are floating point numbers. Sign only shown if negative.

Accelerometer data is provided in G

Gyroscope data is provided in degrees per second

Magnetometer data is provided in micro Tesla

ID5: Impact Subsea Heading, Pitch, Roll, Accelerometer, Gyro, Magnetometer

String format:

$\$ISALL,hhh.h,spp.p,srrr.r,a.aaa,a.aaa,a.aaa,g.ggg,g.ggg,g.ggg,m.mmm,m.mmm,m.mmm*xx<CR><LF>$

s = sign + or -

hhh.h = heading in degrees (0 to 359.9)

pp.p = pitch in degrees (90.0 to -90.0)

rrr.r = roll in degrees (180.0 to -180.0)

a.aaa = Accelerometer reading: X then Y then Z

g.ggg = Gyroscope reading: X then Y then Z

m.mmm = magnetometer reading: X then Y then Z

xx = NMEA standard checksum

ID6: Impact Subsea w, x, y, z, Accelerometer, Gyro, Magnetometer

String format:

```
$ISQUR,w,x,y,z,a.aaa,a.aaa,a.aaa,g.ggg,g.ggg,g.ggg,m.mmm,m.mmm,m.mmm*xx<CR>  
<LF>
```

w= floating point number Q0

x = floating point number Q1

y = floating point number Q2

z = floating point number Q3

a.aaa = Accelerometer reading: X then Y then Z

g.ggg = Gyroscope reading: X then Y then Z

m.mmm = magnetometer reading: X then Y then Z

xx = NMEA standard checksum

7.0 Servicing

The ISD4000 housing is either Acetal or Titanium. Titanium is highly corrosion resistant. The unit is intended to be exceptionally low maintenance.

On a regular basis, the pressure port should be checked and cleaned to ensure salt/silt build-up is minimised.

Following deployment, remove the pressure sensor protective cap locking ring. Once the ring is removed, the protective cap will slide off:



Rinse the pressure and temperature sensor in fresh water until clean. **Avoid physically touching the pressure diaphragm.** Also avoid pulling on the temperature probe – this is held in place by the protective cap. Should the diaphragm suffer from physical damage, this will void the warranty of the ISD4000 unit:



After cleaning, place the protective cap back on the ISD4000 and secure in place with the locking clip.

8.0 Warranty

The ISD4000 is supplied with a Limited Warranty. This warranty applies only to the ISD4000 unit, and only if the ISD4000 is purchased from Impact Subsea Ltd.

What does the limited warranty cover?

This Limited Warranty covers any defects in material or workmanship under normal use during the Warranty Period.

During the Warranty Period, Impact Subsea Ltd will repair or replace, at no charge, products or part of a product that prove defective because of improper material or workmanship under normal use and maintenance.

What will we do to correct the problems?

Impact Subsea Ltd will either replace or repair the Product at no charge, using new or refurbished replacement parts. Replacement or repair is at the discretion of Impact Subsea Ltd.

How long does the coverage last?

The Warranty Period for the ISD4000, purchased from Impact Subsea Ltd, is 1 year from the date of dispatch from Impact Subsea Ltd.

A replacement ISD4000, or part assumes the remaining warranty of the original ISD4000 or 60 days from the replacement or repair, whichever is longer.

What does this limited warranty not cover?

This limited warranty does not cover any problem that is caused by conditions, malfunctions or damage not resulting from the defects in material or workmanship.

What do you have to do?

To obtain a warranty repair of your ISD4000 unit, you must first contact Impact Subsea Support to determine the problem and the most appropriate solution for you.

9.0 Technical Support

Should you require technical support for your ISD4000 unit, our Support team can be contacted as follows:

T. +44 (0) 1224 460 850

E. support@impactsubsea.co.uk

W. www.impactsubsea.com

An out of hours emergency number is available via the Impact Subsea website.

Using the above email address will ensure that a multiple engineers are copied into your support request, and will ensure a prompt response.

When contacting our Support team, please provide the following details of the ISD4000:

- Serial Number
- Firmware version
- Software version (if applicable)
- Fault Description
- Remedial action undertaken thus far

Every effort is made to ensure that information within this document is up to date. However, information within this document is subject to change without notice, in-line with our commitment to continuous product development and improvement.